

Technical Datasheet



Low Specification Diaphragm Operated Pressure Difference Switches **310/316 models**

- Die cast weatherproof enclosure to IP66 (NEMA 4).
- Stainless steel mechanism.
- Internal tamperproof set point adjustment.
- Calibrated scale.
- Set point adjustment from -2.5mbar (-1 in H_2O) up to 1.6 bar (20 psi) dependent on model.



Performance **characteristics**

Enclosure

- IP66 Protection

Wetted parts options

- Flanges pressure die cast zinc alloy – seals nitrile. (310)
- Flanges die cast aluminium alloy – seals nitrile. (316)

Standard Electrical ratings

- Refer to table 6

Process connection

- Rc $\frac{1}{4}$ (1/4 BSP internal).

Unit weight

- Between 1kg – 1.4kg (2.2lb – 3lb)

Accuracy

- Set point repeatability $\pm 1\%$ of span at $20\text{ }^\circ\text{C}$ / $68\text{ }^\circ\text{F}$ ambient.
- Scale accuracy $\pm 3\%$ of full scale.

Product **applications**

The 310/316 is suitable for a wide range of applications in many Industry sectors:

- Oil & Gas
- Chemical
- Petrochemical
- Refining
- Power
- Food Industry

How can we **help you?**

Delta Mobrey range of reliable pressure and temperature measurement instruments can be customised to meet individual requirements. For technical advice or to discuss your application please contact us on +44 (0) 1252 729 140

Enclosure

FINISH

All enclosures are finished in light grey epoxy resin paint.

INTRINSIC SAFETY

Because of the low voltages and currents of I.S. circuits, we recommend using gold contacts.

TABLE 1

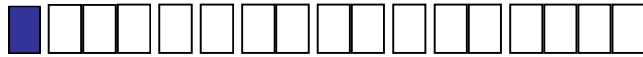

ENCLOSURE	Code
General Purpose Weatherproof The basic enclosure is pressure die-cast in zinc alloy, offering weather protection not less than NEMA type 4 + 13/IP66.	W

Models

NOTE: For pressure difference switches, maximum working pressure (P_{max}) and maximum static/line pressure mean the same.

TABLE 2



	Code
Static/line pressure from -500 (-7psi) to +500mbar (+7psi) Maximum out of balance pressure: 60mbar (25in.H ₂ O) On ranges up to 25mbar (10in. H ₂ O) and 100mbar (40in. H ₂ O) On ranges up to 75mbar (30in. H ₂ O)	310
Static/line pressure from full vacuum -1000mbar (-30in. Hg) to 15 bar (217psi). Maximum out of balance pressure 7bar(100psi)	316

Electrical Entry

Adaptors are available for other popular thread sizes.

TABLE 3

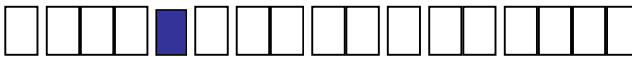

	Code
Clearance for 20mm (3/4in) outside dia conduit.	1
M20 x 1.5 elbow adaptor.	0

Material of Wetted Parts

TABLE 4

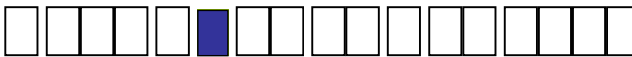

	Code
Model 310 Flanges pressure die cast zinc alloy. Diaphragm and seals are nitrile.	C
Models 316 Flanges die cast aluminium alloy. Diaphragm and seals are nitrile.	D

Setting Ranges

TABLE 5

P_{max} – maximum working pressure

MODEL 310

P_{max} mbar psi		RANGE			Code
		mbar	Code	in. H ₂ O	
500	7	-2.5 to +2.5	B3	-1 to +1	BN
		0 to 5	B5	0 to 2	BR
		0 to 15	C2	0 to 6	C4
		0 to 25	C5	0 to 10	C9
		7.5 to 75	D5	3 to 30	D9

MODEL 316

P_{max} bar psi		RANGE			Code
		mbar/bar	Code	in. H ₂ O / psi	
15	217	0 to 60	D2	0 to 25	D4
		0 to 100	D8	0 to 40	DH
		0 to 400	F1	0 to 160	F4
		0 to 1.0	G0	0 to 15	GB
		0 to 1.6	G8	0 to 20	GZ

Switching Options

TABLE 6

Model 310 & 316 – a much wider variety of switching options is available on Model 306.

UL/CSA Rating (RESISTIVE) §SEE NOTE	IEC 947-5-1/EN 60947-5-1 Rating						Contact	Code
	Designation & Utilization Category	Rated operational current I_e (A) at rated operational voltage U_e	U_i	U_{imp}	VA Rating			
					Make	Break		
5 Amps @ 110/250V AC Light Duty for AC only	AC14 D300 DC13 R300	0.6/0.3A @ 120/240V AC 0.22/0.1A @ 125/250V DC	250V	0.8kV	432 28	72 28	SPDT	00
5 Amps @ 110/250V AC & 2 Amps @ 30V DC General purpose precision	AC14 D300 DC13 R300	0.6/0.3A @ 120/240V AC 0.22/0.1A @ 125/250V DC	250V	0.8kV	432 28	72 28	SPDT	02
1 Amp @ 125V AC & §100mA @ 30V DC gold alloy contacts for low voltage switching	1 A @ 125 VAC RESISTIVE (IEC 1058-1/EN 61058-1)						SPDT	04

The electrical rating is dependent on the microswitch fitted to the instrument. The electrical ratings defined by each approval that the microswitch complies with and is shown on the product nameplate, ie UL/CSA, or IEC. It should be noted that the instrument must be used within the electrical rating specified from the approval you require. This table lists the actual IEC ratings against the Designation & Utilization Category marked on the nameplates. In the absence of any verification by UL/CSA the microswitch § manufacturer's rating is stated in **italics and bold**. **If in doubt seek guidance from the factory.**

NOTE: For low energy circuits e.g. 30V and up to 100mA, we recommend using gold alloy contact switches.

U_i = rated insulation voltage U_{imp} = rated impulse withstand voltage across contacts.

Process Connection

TABLE 7

NOTE: For other thread sizes specify adaptors.

	Code
Rc 1/4 (1/4 BSP tr INT) to (ISO 7/1)	A

Options & Treatments

TABLE 8

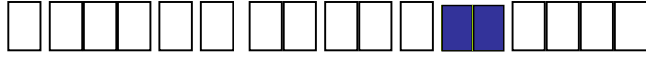

	Code
Tagging - Variety of tagging methods are available	APPLY FOR DETAILS
Applies when – no option is required and selection is made from special engineering.	00

Special Engineering

TABLE 9

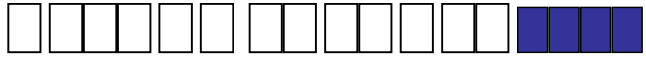

FEATURE	Code
Please consult Delta sales engineering for special requirements.	TBA

Performance Data

TABLE 10

Bar / mbar Units

FIXED SWITCHING DIFFERENTIAL

Due to manufacturing tolerances the figures in these tables are for guidance only. Should the differential be critical for specific applications, our engineers should be consulted prior to ordering.

MODEL 310 – Switch options Table 6

Range Code	00 mbar	02 mbar	04 mbar
B3	0.25	0.8	0.4
B5	0.25	0.8	0.4
C2	0.25	1	0.5
C5	0.25	1	0.5
D5	1.25	5	2.5

MODEL 316 – Switch options Table 6

Range Code	00 mbar	02 mbar	04 mbar
D2	1.5	6	3
D8	1.5	6	3
F1	3	12	6
G0	12.5	50	25
G8	12.5	50	25

PSI Units

MODEL 310 – Switch options Table 6

Range Code	00 in.H ₂ O	02 in.H ₂ O	04 in.H ₂ O
BN	0.1	0.32	0.16
BR	0.1	0.32	0.16
C4	0.1	0.40	0.2
C9	0.1	0.40	0.2
D9	0.5	2	1

MODEL 316 – Switch options Table 6

Range Code	00 in.H ₂ O / psi	02 in.H ₂ O / psi	04 in.H ₂ O / psi
D4	0.6	2.4	1.2
DH	0.6	2.4	1.2
F4	1.2	4.8	2.4
GB	0.18	0.72	0.36
GZ	0.18	0.72	0.36

Technical Specifications

ACCURACY

Set point repeatability $\pm 1\%$ of full scale at 20°C ambient.
Scale accuracy $\pm 3\%$ of full scale.

AMBIENT TEMPERATURE RANGE

All models are suitable for operating within a range of ambient temperature from -25 to +60°C (-13 to +140°F).

ELECTRICAL CONNECTIONS

Earthing/Grounding

An earthing/grounding stud is provided inside the enclosure adjacent to the entry

Dielectric Strength

The electrical assembly is capable of withstanding 2kV between live parts and earth/ground and 500V between open contacts.

OPTIONAL EXTRAS

Mounting

Position/Location/Installation
Vertical as shown, taking care to avoid siting in locations that transmit excessive shock or vibration. For further advice contact our engineers.

Pollution degree (EN60947-5-1)

All products are suitable for use in pollution degree 3.

Electrical Isolation – These products are not suitable for electrical isolation. Always isolate circuit separately to carry out any electrical work.

Unit Weights

(Approx.) – Model	
310	1kg / 2.2lb
316	1.4kg / 3lb

Dimensions

All dimensions mm (Inches)

Model 310

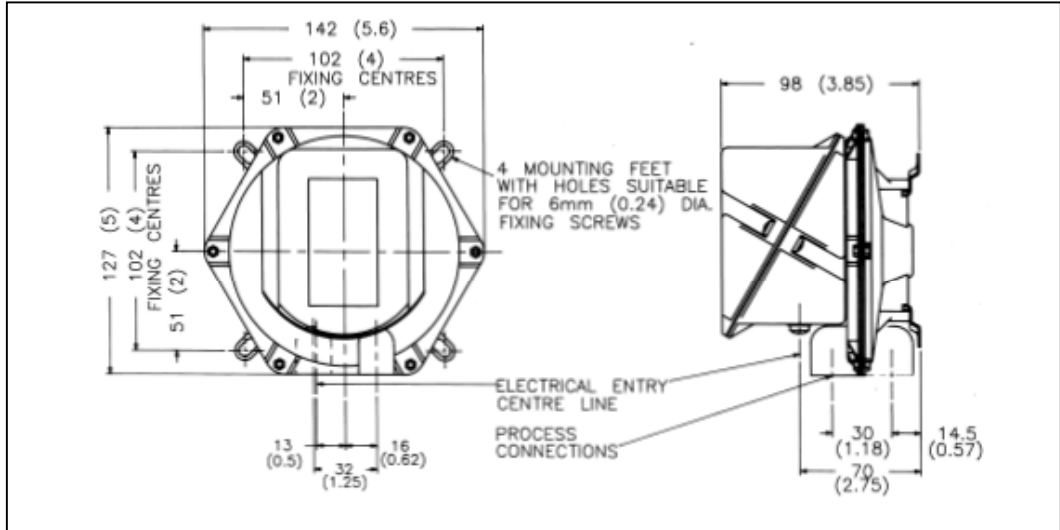

Model 316

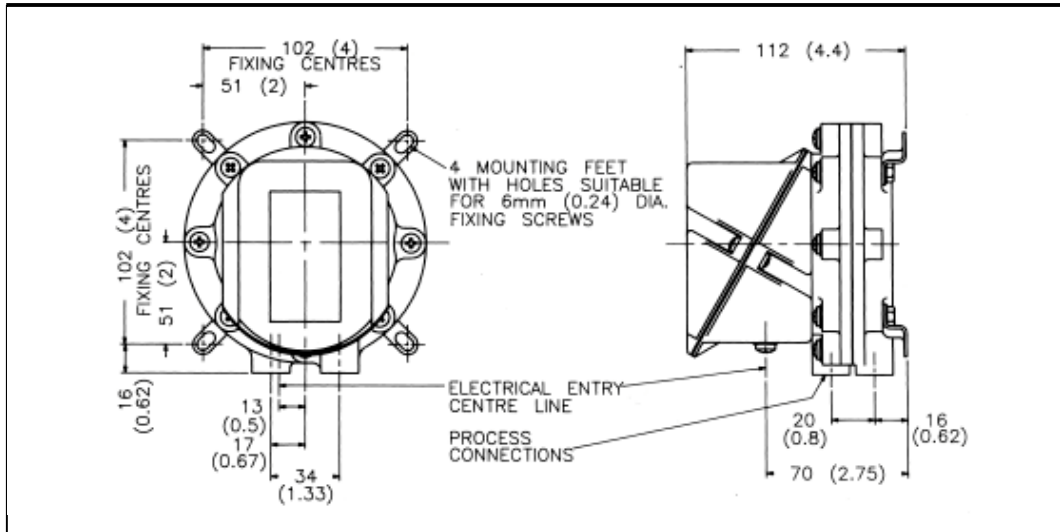

In the interest of development and improvement Delta Mobrey Ltd, reserves the right to amend, without notice, details contained in this publication. No legal liability will be accepted by Delta Mobrey Ltd for any errors, omissions or amendments.

Delta Mobrey Limited

Riverside Business Park, Dogflud Way, Farnham, Surrey GU9 7SS, UK.

T+44 (0)1252 729 140 F+44 (0)1252 729 168 [E sales@delta-mobrey.com](mailto:sales@delta-mobrey.com) [W www.delta-mobrey.com](http://www.delta-mobrey.com)



FM00720