



PowerDyne[®] STEAM TRAP

MODEL P21S ver.C

COMPACT THERMODYNAMIC DISC TRAP FOR TRACING SERVICE

Benefits

Stainless steel trap includes Y-strainer for reliable performance in tracing and instrumentation.

1. Single enlarged outlet port to extend reliability in copper tube tracing applications.
2. Built-in Y-strainer for consistent performance.
3. Installing an optional blowdown valve enables easy removal of scale and obtaining a "Zero Energy" condition for maintenance.
4. Hardened stainless steel working surfaces for long service life.
5. Air-jacketing reduces no-load cycling and extends service life.
6. Lapped disc provides steam-tight seal for long service life.



With optional BD1

Specifications

Model	P21S ver.C	
Connection	Screwed	
Size (in)	1/4, 3/8, 1/2	
Maximum Operating Pressure (psig) PMO	300	
Minimum Operating Pressure (psig)	Horizontally installed: 3.5	Vertically installed: 6
Maximum Operating Temperature (°F) TMO	800	
Maximum Allowable Pressure (psig) PMA	650	
Maximum Allowable Temperature (°F) TMA	800	
Maximum Back Pressure	80% of Inlet Pressure	

Connections and sizes in bold are standard



CAUTION

To avoid abnormal operation, accidents or serious injury, DO NOT use this product outside of the specification range. Local regulations may restrict the use of this product to below the conditions quoted.

No.	Description	Material	ASTM/AISI*	JIS
①	Body	Cast Stainless Steel	A743 Gr.CA40	—
② ^R	Cover	Stainless Steel	AISI420F2	SUS420F2
③ ^R	Disc	Hardened Stain. Steel	AISI420	SUS420J2
④ ^R	Screen	Stainless Steel	AISI430	SUS430
⑤ ^{MR}	Screen Holder Gasket	Stainless Steel	AISI316L	SUS316L
⑥	Screen Holder	Stainless Steel	AISI303	SUS303
⑦ ^R	Cap	Stainless Steel	AISI304	SUS304
⑧ ^R	Nameplate	Stainless Steel	AISI304	SUS304
⑨	BD1 Blowdown Valve**	Stainless Steel	AISI304	SUS304

* Equivalent ** Option

Replacement kits available: (M) maintenance parts, (R) repair parts,

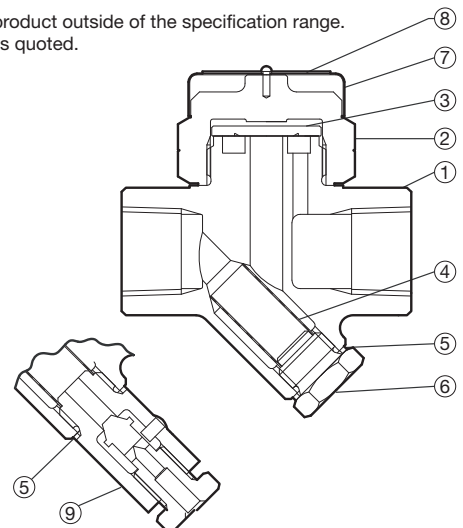

Dimensions

● **P21S ver.C Screwed**

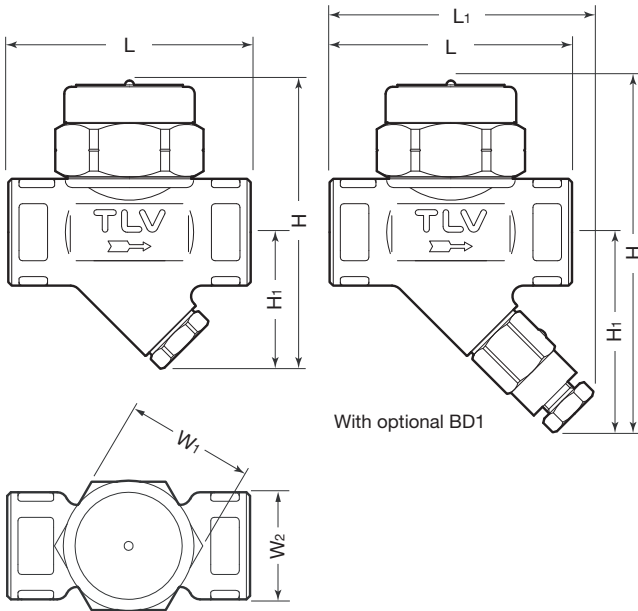

P21S ver.C Screwed* (in)

Size	L	L ₁	H	H ₁	W ₁	W ₂	Weight (lb)
1/4	2	2 ^{11/16}	3	1 ^{7/16}	1 ^{3/8}	1 ^{5/16}	0.8 (0.9)
3/8			3 ^{3/4}	2 ^{3/16}			
1/2	2 ^{11/16}	2 ^{15/16}	3 ^{1/4} (4)	1 ^{1/2} (2 ^{1/4})			

* NPT, other standards available
() with optional BD1

Discharge Capacity

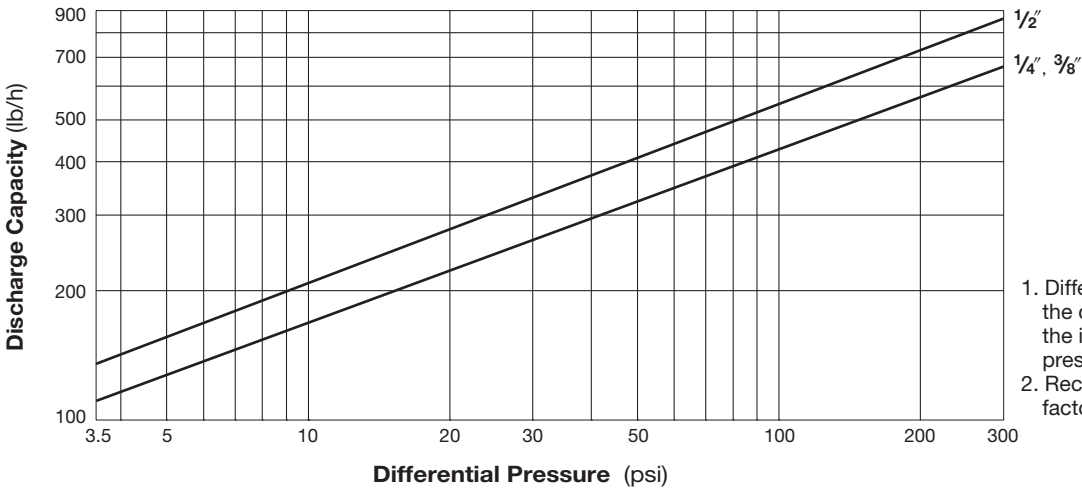

1. Differential pressure is the difference between the inlet and outlet pressure of the trap.
2. Recommended safety factor: at least 2.



DO NOT DISASSEMBLE OR REMOVE THIS PRODUCT WHILE IT IS UNDER PRESSURE.
Allow internal pressure of this product to equal atmospheric pressure and its surface to cool to room temperature before disassembling or removing. Failure to do so could cause burns or other injury. READ INSTRUCTION MANUAL CAREFULLY.

TLV CORPORATION

13901 South Lakes Drive, Charlotte, NC 28273-6790
Tel: 704-597-9070 Fax: 704-583-1610
E-mail: tlv@tlvengineering.com <https://www.tlv.com>
For Technical Service 1-800 "TLV TRAP"



Manufacturer
TLV CO., LTD.
Kakogawa, Japan
is approved by LRQA Ltd. to ISO 9001/14001

