

# P77 Series Controls for Low Pressure Applications

## Installation Instructions

P77AAA, P77BCA

Part No. 24-7664-3167, Rev. A  
Issued September 2018

Refer to the [QuickLIT website](#) for the most up-to-date version of this document.

### Applications

P77 Series Controls for Low Pressure Applications provide low pressure control of compressors on commercial refrigeration and air-conditioning applications.

**IMPORTANT:** Use this P77 Series Control only as an operating control. Where failure or malfunction of the control could lead to personal injury or property damage to the controlled equipment or other property, additional precautions must be designed into the control system. Incorporate and maintain other devices, such as supervisory or alarm systems or safety or limit controls, intended to warn of or protect against failure or malfunction of the control.

**IMPORTANT :** Utiliser P77 Series Control uniquement en tant que dispositif de contrôle de fonctionnement. Lorsqu'une défaillance ou un dysfonctionnement du contrôle risque de provoquer des blessures ou d'endommager l'équipement contrôlé ou un autre équipement, la conception du système de contrôle doit intégrer des dispositifs de protection supplémentaires. Veiller dans ce cas à intégrer de façon permanente d'autres dispositifs, tels que des systèmes de supervision ou d'alarme, ou des dispositifs de sécurité ou de limitation, ayant une fonction d'avertissement ou de protection en cas de défaillance ou de dysfonctionnement du contrôle.

P77 control models are typically used for low pressure Cut-out applications and pump-down control. Single-Pole, Double-Throw (SPDT) switches allow you to install alarm devices or other control circuits. Automatic Reset P77AAA Type models can also be wired for low-pressure Cut-in operation.

These controls are available in several pressure ranges and are compatible with most common refrigerants. They may also be used on air, water, and other non-corrosive fluid applications.

Low-pressure P77BCA Type models with Manual Reset Lockout lock out when the Cut-out pressure is reached and do not automatically reset when the pressure rises after Cut-out, providing shutdown capability for unmonitored equipment. See [Manual Reset Operation](#).

Type 1 enclosures are standard on most models.



## Installation

### Dimensions

See Figure 1 for control dimensions. These dimensions are nominal and subject to accepted manufacturing tolerances and application variables.

**Figure 1: Dimensions of P77 Low Pressure Control with Type 1 Enclosure, in. (mm)**

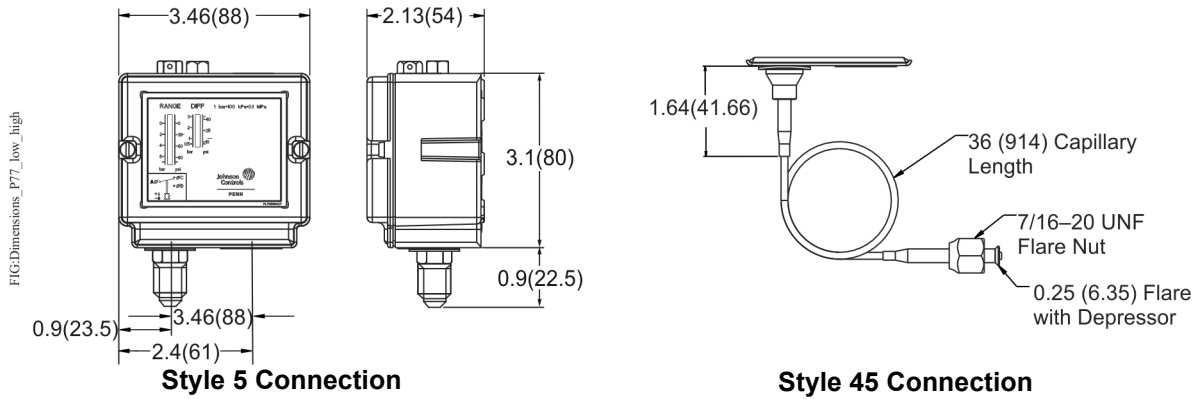

## Mounting

### NOTICE

#### Risk of Property Damage.

Mount the P77 Low Pressure Control according to the instructions and guidelines included with the control. These instructions and guidelines are intended to reduce the risk of malfunction of the control and resulting property damage. Failure to follow these instructions and guidelines could cause the control to malfunction, resulting in property damage.

### NOTICE

#### Risque de dégâts matériels.

Montez le contrôle P77 selon les instructions et directives fournies avec le contrôle. Ces instructions et directives sont destinées à réduire les risques de mauvais fonctionnement du contrôle et de dégâts matériels. Le non-respect de ces instructions et directives pourrait provoquer un dysfonctionnement du contrôle et causer des dégâts matériels.

**IMPORTANT:** When mounting the control to a flat horizontal surface, use the screws provided and Universal Mounting Bracket (sold separately) to avoid damaging internal components. Be careful not to distort or bend the control case when mounting the control to an uneven surface. Using other screws or bending the control case will void the warranty.

**Guidelines:** Observe the following guidelines to mount the P77 low pressure control:

- Mount the control in an accessible position, where the control and pressure-connection lines are not subject to damage.
- Mount the pressure control upright and level.
- Position the pressure-connection lines to allow drainage away from the control bellows.
- Locate pressure-tap points on the topside of the refrigerant lines to reduce the possibility of oil, liquids, or sediment accumulating in the bellows, which could cause control malfunction.
- Mount controls with Type 1 enclosures on horizontal or vertical flat surfaces.

**Vertical Surface:** Use four M4 x 6 mm + d screws (1) through the inner holes (2) on the back of the control case when mounting directly to a flat vertical surface (3). The screws cannot be longer than 6 mm + d (where d refers to thickness of mounting surface). (See Figure 2 and Table 1.)

**Horizontal Surface:** Use four M4 x 6 mm screws provided (4) and Universal Mounting Bracket (5) (sold separately) when mounting to a flat horizontal surface (See Figure 2 and Table 1).

**Figure 2: Mounting the P77 Low Pressure Control**

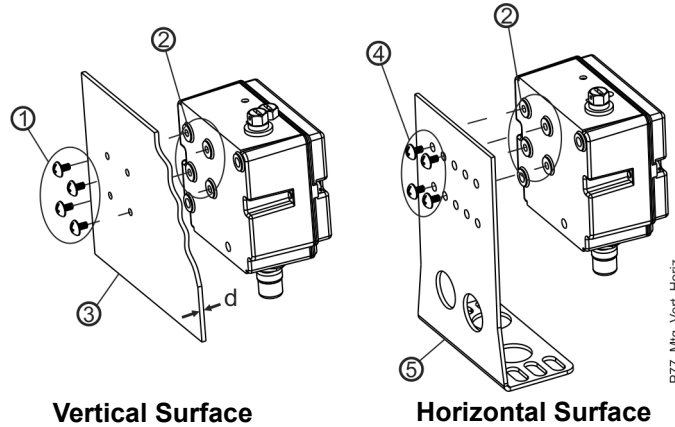

**Table 1: Mounting the P77 Low Pressure Control**

Callout	Description
1	Mounting Screws for Vertical Surface (4), M4 x 6 mm + d (screws cannot be longer than 6 mm + d)
2	Inner Mounting Holes (4)
3	Flat Vertical Mounting Surface
4	Mounting Screws for Horizontal Surface (4), M4 x 6 mm (Provided)
5	Universal Mounting Bracket (Part Number 271-51, Sold Separately)

**Wiring**

**⚠ WARNING**

**Risk of Electric Shock.**

Disconnect or isolate all power supplies before making electrical connections. More than one disconnection or isolation may be required to completely de-energize equipment. Contact with components carrying hazardous voltage can cause electric shock and may result in severe personal injury or death.

**⚠ AVERTISSEMENT**

**Risque de décharge électrique.**

Débrancher ou isoler toute alimentation avant de réaliser un branchement électrique. Plusieurs isolations et débranchements sont peut-être nécessaires pour -couper entièrement l'alimentation de l'équipement. Tout contact avec des composants conducteurs de tensions dangereuses risque d'entraîner une décharge électrique et de provoquer des blessures graves, voire mortelles.

**IMPORTANT:** Use copper conductors only. Make all wiring connections in accordance with local, national, and regional regulations. Do not exceed the control's electrical ratings.

**IMPORTANT:** Use terminal screws furnished in the switch block. Using other terminal screws will void the warranty and may damage the switch.

P77 controls for low pressure applications are available with a Single-Pole, Double-Throw (SPDT) switch. Check the label inside the control cover for the model number, switch action, and electrical rating. Check the wiring terminal designations on the control switch block, and see the following wiring diagram when wiring the control. (See Figure 3 and Table 2). Also see [Technical Specifications](#).

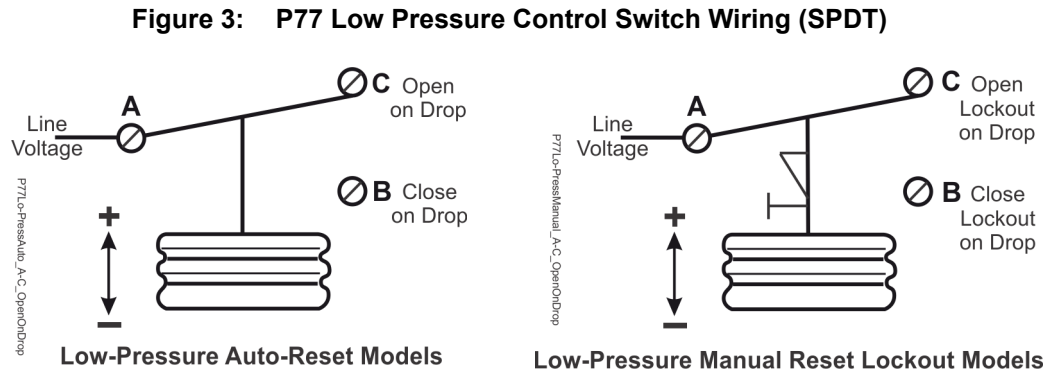

**Table 2: Single Pressure Control, Low Events, and High Events**

Switch and Action	Low Event on Pressure Drop	High Event on Pressure Rise
Single-Pole, Double-Throw (SPDT)	A to C Opens (Cut-out at Low Event) A to B Closes (Cut-in at Low Event)	A to C Closes (Cut-in at High Event) A to B Opens (Cut-out at High Event)

## Refrigerant Connections

### NOTICE

#### Risk of Environmental and Property Damage.

Avoid sharp bends in the capillary tubes. Sharp bends can weaken or kink capillary tubes, which may result in refrigerant leaks or restrictions of flow.

### NOTICE

#### Risque de dommages environnementaux et dégâts matériels.

Éviter de former des coudes serrés avec les tubes capillaires. Les coudes serrés peuvent affaiblir les tubes capillaires ou engendrer des pliures, ce qui risque de provoquer des fuites de réfrigérant ou d'en gêner l'écoulement.

## NOTICE

### **Risk of Environmental and Property Damage.**

Coil and secure excess capillary tubing away from contact with sharp or abrasive objects or surfaces. Vibration or sharp or abrasive objects in contact with capillary tubes can cause damage that may result in refrigerant leaks, which may result in damage to the environment or property.

## NOTICE

### **Risque de dommages environnementaux et dégâts matériels.**

Enrouler et fixer l'excédent de tubes capillaires de manière à éviter tout contact avec des objets coupants ou des surfaces abrasives. Des vibrations ou des objets coupants ou abrasifs en contact avec les tubes capillaires risquent d'endommager ceux-ci et d'occasionner des fuites de réfrigérant, susceptibles de provoquer des dommages environnementaux ou des dégâts matériels.

**IMPORTANT:** If the control is installed on equipment that contains hazardous or regulated materials such as certain refrigerants or lubricants, you must comply with all standards and regulations governing the containment and handling of those materials.

**IMPORTANT:** Do not apply more than 9 ft·lb (12 N·m) of torque to the flare nuts on pressure connection line fittings. Over-tightening or applying more than 9 ft·lb (12 N·m) of torque may cause seal failure and will void the warranty.

P77 low pressure controls with a Style 5 connection are connected to the controlled equipment by a capillary. Capillaries are available from Johnson Controls, Inc. Refer to *SEC99A, UltraCap Armored Capillary LIT-1900131* for more information.

Install pressure connection to pressure-tap points away from the compressor, to minimize the effects of pressure pulsation from reciprocating compressors.

**IMPORTANT:** After installing the control, evacuate pneumatic and pressure connection lines to remove air, moisture, and other contaminants in a manner consistent with applicable environmental regulations and standards.

## Setup and Adjustments

## NOTICE

### **Risk of Property Damage.**

Obtain and use the compressor manufacturer's net oil bearing pressure specifications. If necessary, reset the Cut-out pressure difference to the manufacturer's specifications. Using improper pressure settings may damage the control, compressor, or other controlled equipment.

## NOTICE

### **Risque de dégâts matériels.**

Consulter et utiliser les spécifications de pression nette de palier à huile fournies par le fabricant du compresseur. Si nécessaire, réinitialiser la différence de pression d'ouverture sur les paramètres spécifiés par le fabricant. L'utilisation de paramètres de pression inappropriés risque d'endommager le dispositif de contrôle, le compresseur ou d'autres équipements contrôlés.

**IMPORTANT:** Use the pressure control settings recommended by the manufacturer of the controlled equipment. Do not exceed the pressure ratings of the controlled equipment or any of its components when checking pressure control operation or operating the controlled equipment.

**IMPORTANT:** After mounting, wiring, and evacuating the control, attach a reliable set of gauges to the controlled equipment, and operate the equipment (at least) three cycles at the pressures necessary to verify control setpoints and proper equipment operation.

**IMPORTANT:** Do not adjust pointers beyond the highest or lowest indicator marks on the control's pressure scale. Adjusting pointers beyond indicator marks may damage screw threads, may cause inaccurate control operation, and will void the warranty.

### **Adjusting the P77 Low Pressure Controls**

Use the following procedures for adjusting these controls. Refer to the product label inside the control cover for model number and switch action. See Table 2 for switch action, low event, and high event.

**Low Pressure Cut-out - Automatic Reset:** Models with Automatic Reset have a scaleplate that displays the Cut-in and Differential setpoints (Item 1, Figure 4).

1. Set the Cut-in setpoint (High Event; A closes to C) by adjusting the range screw (2).
2. Turn the range screw clockwise to raise the Cut-in setpoint.
3. Set the Cut-out setpoint (Low Event; A opens to C) by adjusting the differential screw (3).
4. Turn the differential screw clockwise to lower the Cut-out setpoint.

**Note:** Cut-out is equal to Cut-in minus Differential.

**Low Pressure Cut-out - Manual Reset Lockout:** Models with Manual Reset Lockout have a scaleplate that displays the Cut-out setpoint (Item 4, Figure 4). There is no pointer for the Cut-in setpoint.

1. Set the High Event by adjusting the range screw (2).
2. Turn the range screw clockwise to raise the High Event.

**Note:** There is no Differential adjustment on Manual Reset Lockout models. The Differential pressure on P77 Low Pressure models is fixed at 7 psi (0.5 bar).

3. See [Manual Reset Operation](#) to restart controlled equipment (see Item 5, Figure 4).

**Figure 4: Adjusting P77 Controls for Low Pressure Applications**

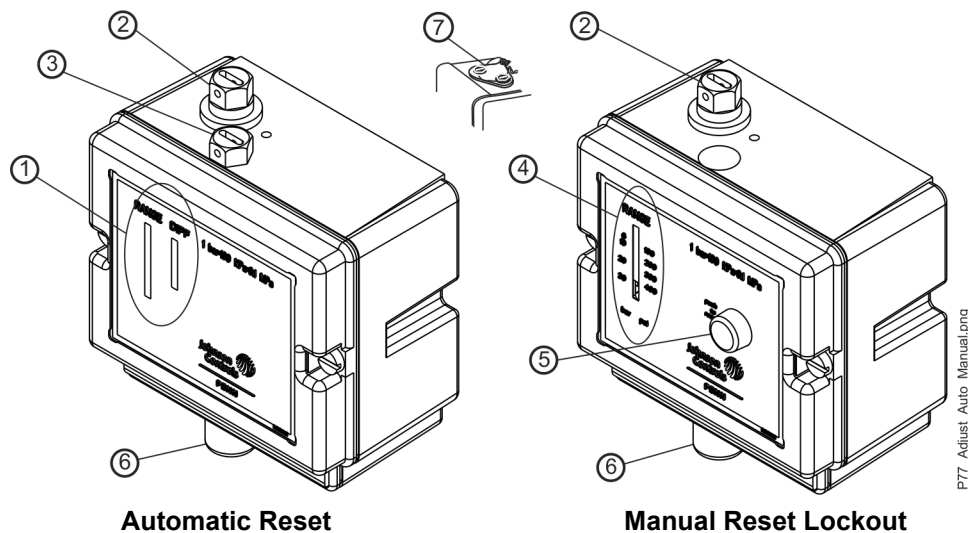

**Table 3: Adjusting P77 Low Pressure Controls**

Callout	Description
1	Range and Differential Scales
2	Range Screw
3	Differential Screw
4	Range Scale (only)
5	Reset Button
6	Pressure Connection
7	Adjustment Lock Plate (if applied)

**Checkout Procedure for P77 Low Pressure Controls**

**IMPORTANT:** Use the pressure control settings recommended by the manufacturer of the controlled equipment. Do not exceed the pressure ratings of the controlled equipment or any of its components when checking pressure control operation or operating the controlled equipment.

**IMPORTANT:** After installing the control, attach a reliable set of gauges to the controlled equipment, and operate the equipment (at least) three cycles at the pressures necessary to verify control setpoints and proper equipment operation.

**Manual Reset Operation**

Pressure controls with the Manual Reset option lock out when they reach Cut-out pressure and must be manually reset by the user to restart the controlled equipment. The manual reset mechanism is trip-free and cannot be overridden by holding the Reset Button down.

When a control requires a manual reset, first determine what caused the control to cut out, and allow the sensed pressure to rise at least 7 psi (0.5 bar) above the Cut-out pressure. Then press and release the Reset Button on the front of the control to restore normal operation of the controlled equipment (see Item 5, Figure 4).

**Technical Specifications**

**Table 4: P77 Series Electrical Ratings**

Volts AC 50/60 Hz	UL60730						
	24	120		208		240	
	–	Primary Contact	Secondary Contact	Primary Contact	Secondary Contact	Primary Contact	Secondary Contact
Horsepower	–	1	0.33	1	0.75	1	1
Full Load Amperes	–	16	7.2	9.2	7.6	8	8
Locked Rotor Amperes	–	96	43.2	55.2	45.6	48	48
Resistive Amperes	16	16	8	10	8	10	8
Pilot Duty VA	125	720	720	720	720	720	720

**Note:** When the Primary Contact is A–C, the Secondary Contact is A–B. When the Primary Contact is A–B, the Secondary Contact is A–C.

**Table 5: P77 Series Applications**

Information	Description
Product Switch Action	Single-Pole, Double-Throw (SPDT)
Pressure Connection	7/16-20 UNF for 1/4 (6 mm) flare nut
Ambient Conditions	Temperature: -40 to 140°F (-40 to 60°C) Humidity: 0 to 95% R.H. Non-condensing
Enclosure	Type 1: Cast Aluminum
Dimensions (H x W x D)	Type 1 Enclosure: 4 x 3.5 x 2.5 in. (101 x 89 x 64 mm)
Approximate Shipping Weight	Individual Pack: (Type 1 Enclosure): 1.1 lbs (0.5 kg) Bulk Pack: (Type 1 Enclosure in multiples of 35 controls): 40 lbs (18.1 kg)
Compliance	cULus Listed; UL 60730, File SA516

**Table 6: UL Conformity Declaration Information**

Information	Description
Purpose of Control	Pressure Operating Control: Automatic reset controls Pressure Cut-Out: Manual reset controls
Construction of Control	Electromechanical
Number of Cycles	Automatic: 30,000 Cycles Manual Reset: 6,000 Cycles
Method of Mounting Control	Independently-mounted control
Type 1 or Type 2 Action	Automatic: Type 1; Type 1.C (Micro-Interruption) Manual Reset: Type 2
Pollution Degree	Category 3
Heat and Fire Resistance Category	N/A
Rated Impulse Voltage	4,000 V
Ball Pressure Temperature	N/A
Field Wiring Rating	194°F (90°C)
Maximum Working Pressure	290 psi (20 bar)
Cover Screw Torque Requirements Instruction	Tighten Enclosure Screws to: 10 - 12 in·lb (1.1 - 1.4 N·m)

*The performance specifications are nominal and conform to acceptable industry standards. For application at conditions beyond these specifications Johnson Controls shall not be liable for damages resulting from misapplication or misuse of its products.*

**European Single Point of Contact:**

JOHNSON CONTROLS  
WESTENDHOF 3  
45143 ESSEN  
GERMANY

**NA/SA Single Point of Contact:**

JOHNSON CONTROLS  
507 E MICHIGAN ST  
MILWAUKEE WI 53202  
USA

**APAC Single Point of Contact:**

JOHNSON CONTROLS  
C/O CONTROLS PRODUCT MANAGEMENT  
NO. 22 BLOCK D NEW DISTRICT  
WUXI JIANGSU PROVINCE 214142  
CHINA



[www.penncontrols.com](http://www.penncontrols.com)

© Johnson Controls and PENN are registered trademarks of Johnson Controls in the United States of America and/or other countries. All other trademarks used herein are the property of their respective owners. © Copyright 2018 by Johnson Controls. All rights reserved.