



# BPW32 Balanced Pressure Wafer Steam Trap

## Description

The BPW32 is a compact wafer pattern stainless steel balanced pressure steam trap for pressures up to 21 bar g. It has an internal strainer, is maintainable and is suitable for installation between two pipeline flanges. It offers both weight and space savings over conventional traps.

## Capsule filling and operation

**Standard capsules** are marked with the letters 'STD' for operation at approximately 13 °C below steam saturation temperature.

**Optionally**, the capsule can be supplied for sub-cooled operation with a 'SUB' fill which operates at approximately 24 °C below steam saturation temperature or for near-to-steam a 'NTS' fill which operates at approximately 6 °C below steam saturation temperature.

## Standards

This product fully complies with requirements of the European Pressure Equipment Directive 97/23/EC.

## Certification

This product is available with certification to EN 10204 3.1.

**Note:** All certification/inspection requirements must be stated at the time of order placement.

## Sizes and pipe connections

DN15, DN20 and DN25 to fit between standard flanges PN40, ANSI 150, ANSI 300, JIS 10, JIS 16 and JIS 20.

## Pressure/temperature limits (ISO 6552)

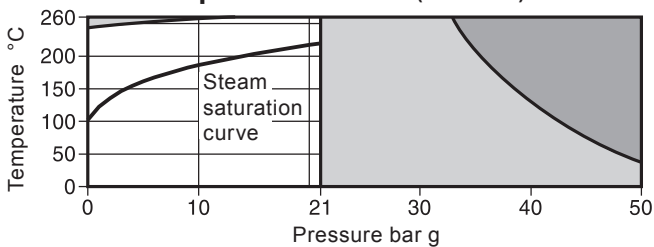

- The product **must not** be used in this region.
- The product should not be used in this region or beyond its operating range as damage to the internals may occur.

Body design conditions	PN50/ANSI 300
PMA Maximum allowable pressure	50 bar g @ 38 °C
TMA Maximum allowable temperature	260 °C @ 33 bar g
Minimum allowable temperature	0 °C
PMO Maximum operating pressure	21 bar g @ 260 °C
TMO Maximum operating temperature	260 °C @ 21 bar g
Minimum operating temperature	0 °C
<b>Note:</b> For lower operating temperatures consult Spirax Sarco	
Designed for a maximum cold hydraulic test pressure of 75 bar g	

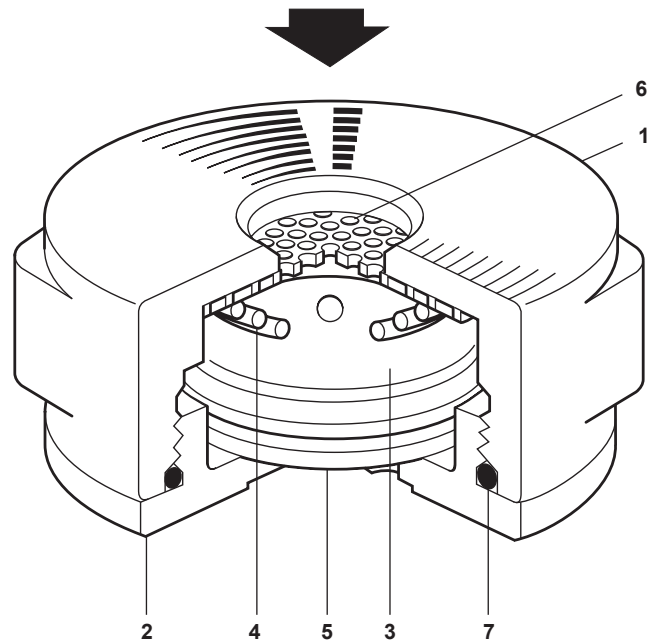

## Materials

No.	Part	Material
1	Body	Stainless steel DIN 17445 1.4408/ ASTM A351 CF8M
2	Cap	Stainless steel EN10088 1.4057/ ASTM A479 431
3	Capsule	Stainless steel
4	Spring	Stainless steel BS 2056 302 S26
5	Spacer plate	Stainless steel BS 1449 304 S16
6	Strainer screen 0.8 mm perforations	Stainless steel ASTM A240 316L
7	'O' ring	EPDM

## Dimensions/weights (approximate) in mm and kg

Size	PN40	ANSI 150	ANSI 300	JIS	ANSI 300		ANSI 300		Weight
	A	A	A	A	ANSI 150 B	PN40/JIS B	ANSI 150 C	PN40/JIS C	
<b>DN15</b>	53	-	55	58	47	53	25.5	25.5	0.30
DN20	63	53	67	63	53	63	25.5	31.5	0.57
DN25	72	53	72	74	62	72	31.5	35.5	0.83

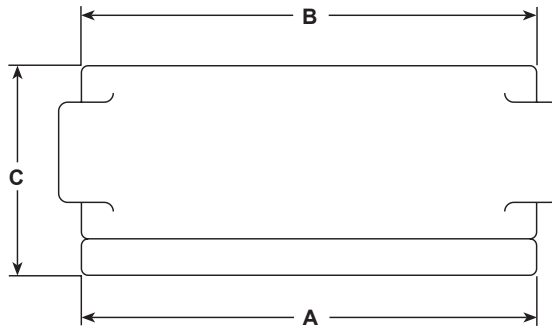

## Capacities

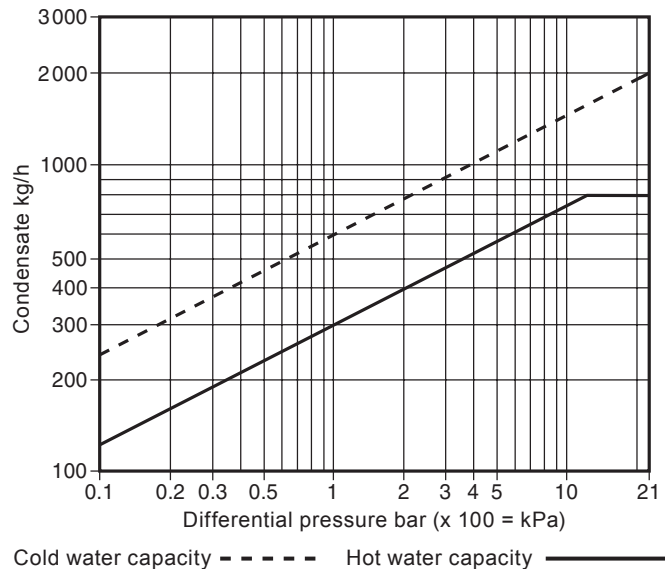

## Safety information, installation and maintenance

For full details see the Installation and Maintenance Instructions (IM-P126-07) supplied with the product.

### Installation note:

The trap is intended for installation in a vertical line with flow from top to bottom, this will ensure that it is self-draining. It can also be installed in other planes if required. Standard flange gaskets are to be used - supplied by customer.

### How to order

**Example:** 1 off Spirax Sarco DN25 BPW32 maintainable wafer pattern balanced pressure steam trap for installation between DIN PN40 flanges. To be supplied with an 'STD' fill capsule. The outer diameter to provide positive location inside flange bolts for ease of installation.

## Spare parts

The spare parts available are shown in solid outline. Parts drawn in a solid grey line are not supplied as spares.

### Available spares

Internal set	3, 4, 5, 6, 7
End cap	2

### How to order spares



Always order spares by using the description given in the column headed 'Available spares' and state the size, model no. and capsule option required.

**Example:** 1 - Internal set for a DN20 BPW32 balanced pressure wafer steam trap with 'STD' fill capsule.

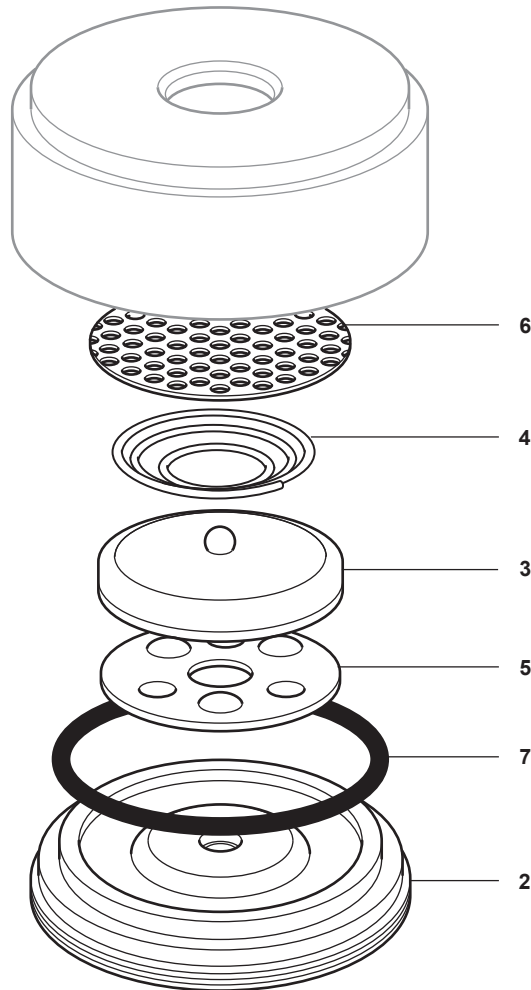
**Note:** The capsule can be identified from the letter stamped on the name-plate of the cap (e.g. **STD**, **SUB** or **NTS**). A standard capsule (**STD**) will be supplied, unless specified otherwise on the order.



## Recommended tightening torques

Item	Connections	Sizes	or		N m
					
1 and 2	ANSI 150	All sizes			10 - 15
	PN40	DN15			10 - 15
	ANSI 300	DN20			15 - 20
	JIS 10				
	JIS 16	DN25			20 - 25