

Mobrey M-Switch

Float Operated Liquid Level Switch



- Reliably detects the liquid level to give a voltage free contact operation for alarm signalling or as part of a pump control system
- Small in-tank dimensions, suitable for use where space in a vessel is limited
- Available for side mounting with either a flanged or 2-in. threaded connection
- Tough industrial build quality with 316 Stainless steel construction throughout
- European directive compliance
- ATEX and IECEx flameproof models (Ex d)

Overview of Mobrey M-Switch



Vertical cylindrical tank with two M-Switches fitted

Introduction

Manufactured in 316 stainless steel throughout, the M-Switch is available for side mounting with either a flange or 2-in. thread.

Comprising a small float on the wetside and a body containing a micro-switch on the dryside, the Mobrey M-Switch reliably detects liquid level to give a voltage-free contact operation for alarm signalling or as part of a pump control system.

Operating principle

One permanent magnet forms part of a float assembly which rises and falls with changing liquid level. A second permanent magnet is positioned within the switch so that the adjacent poles of the two magnets repel each other through the nonmagnetic wall of the switch body.

A change of liquid level which moves the float through its permissible travel will cause the float magnet to move and repel the switch magnet to operate the micro-switch contacts.

Wireless option

All the models in the Mobrey range of float switches are available for use with the Rosemount 702 wireless discrete transmitter, allowing plant managers to cost-effectively access valuable data about the performance and safety of their plant.

Typical applications

- Low level alarms in lubricating oils and fuel oils
- Pump control duty in header tanks
- High and low alarms in condensate tanks
- Level and pump control in storage tanks

Installation

The M-Switch is designed for side mounting either direct into a vessel or in an external chamber.

Choose a position where the effects of turbulence caused by agitators or inlets are minimized. The switch should be positioned so that the float may move freely over its full travel and not foul the sides, bottom, or top of the tank.

A flange or threaded boss is recommended for pressurised applications, designed such that the float is free to move over its full travel.



Mobrey M-Switch

Rosemount 702 wireless discrete transmitter

The advent of wireless communications allows process plant managers to save up to 90% of installation cost compared with wired technologies.

Contents

Overview of Mobrey M-Switch page 2
 Mobrey M-Switch Ordering Information page 3

Specifications page 4
 Dimensional Drawings page 5

Mobrey M-Switch Ordering Information

Specification and selection of product materials, options, or components must be made by the purchaser of the equipment. See [Material selection](#) below for more information.

Table 1. M-Switch ordering information

★The Standard offering represents the most common options. The starred options (★) should be selected for best delivery. The Expanded offering is subject to additional delivery lead time.

Model	Product Description	
SM	M-Switch, 316 Stainless steel construction	
Mounting Arrangement ⁽¹⁾		
Standard		Standard
A	Mobrey 'A' flange	★
D ⁽²⁾	Mobrey 'D' flange	★
B	2-in. BSPT threaded	★
N	2-in. NPT threaded	★
Enclosure		
Standard		Standard
1	Weatherproof IP66/67 (NEMA 4)	★
2 ⁽³⁾	Flameproof ATEX and IECEx, IP66/IP67 (NEMA 4)	★
Typical Model Number: SM B 1		

(1) See [Table 2 on page 4](#) for the maximum pressure rating of each mounting arrangement.

(2) Not available on the flameproof version of the M-Switch.

(3) See "[Specifications](#)" on [page 4](#) for the ATEX and IECEx approval codings.

Material selection

Emerson provides a variety of Mobrey products with various product options and configurations including materials of construction that can be expected to perform well in a wide range of applications. The Mobrey product information presented is intended as a guide for the purchaser to make an appropriate selection for the application. It is the purchaser's sole responsibility to make a careful analysis of all process parameters (such as all chemical components, temperature, pressure, flow rate, abrasives, contaminants, etc.), when specifying product, materials, options and components for the particular application. Emerson Process Management is not in a position to evaluate or guarantee the compatibility of the process fluid or other process parameters with the product, options, configuration or materials of construction selected.

Specifications

General	
Product	M-Switch Float Operated Liquid Level Switch
Minimum liquid specific gravity	0.75
Differential	1 in. (25 mm)
Length into tank	6 in. (153 mm)
Float diameter	Ø1.9 in. (Ø48 mm)
Maximum float swing	4.4 in. (112 mm)
Switching function (See Figure 1)	SPCO (Single-Pole-Change-Over) relay
Construction materials	
Wetside material	316 Stainless steel
Body material	316 Stainless steel
End cover material	316 Stainless steel
Gasket	Non-asbestos for Mobrey 'A' flange Ethylene propylene for Mobrey 'D' flange
Electrical	
Conduit entry	M20 for flanged and BSPT threaded versions ½-in. NPT for NPT threaded versions
Maximum voltage and current	See Table 3 for the maximum voltage and current The microswitch contacts are gold-plated and are suitable for use in low-power circuits. Switching high-power circuits can permanently damage the gold-plating. Not suitable for the direct starting of large motors.
Environment	
Operating temperature	32 to 266 °F (0 to 130 °C)
Ambient temperature	32 to 140 °F (0 to 60 °C)
Operating pressure	See Table 2 for the maximum pressure ratings
Approvals	
Enclosure ratings	Weatherproof M-Switch: IP66/67 (NEMA 4) Flameproof M-Switch: ATEX: II 1/2G Ex d IIC T6 Ga/Gb IECEX: Ex d IIC T6 Ga/Gb IP66/IP67 (NEMA 4)
Marine	Germanischer Lloyd

Table 2. Maximum pressure ratings

Mounting Arrangement	Maximum P @ T _{room}			
	Weatherproof		Flameproof	
Mobrey 'A' flange	275 psi	19 bar	362 psi	25 bar
Mobrey 'D' flange	43 psi	3 bar	Not applicable	
2-in. BSPT threaded	275 psi	19 bar	720 psi	49.6 bar
2-in. NPT threaded	275 psi	19 bar	720 psi	49.6 bar

Table 3. Maximum voltage and current

Maximum voltage and current	AC	DC (Resistive)	DC (Conductive)
Max. voltage (V)	250	250	250
Max. current (A)	15	0.25	15

Figure 1. Switching function

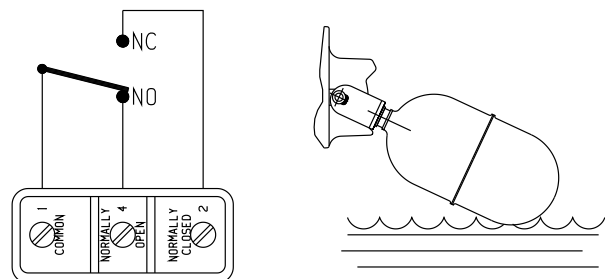

**NO (Normally Open) is made on a falling level.
NC (Normally Closed) is made on a rising level.**

Dimensional Drawings

M-Switch dimensions

Note: Dimensions are in inches (mm).

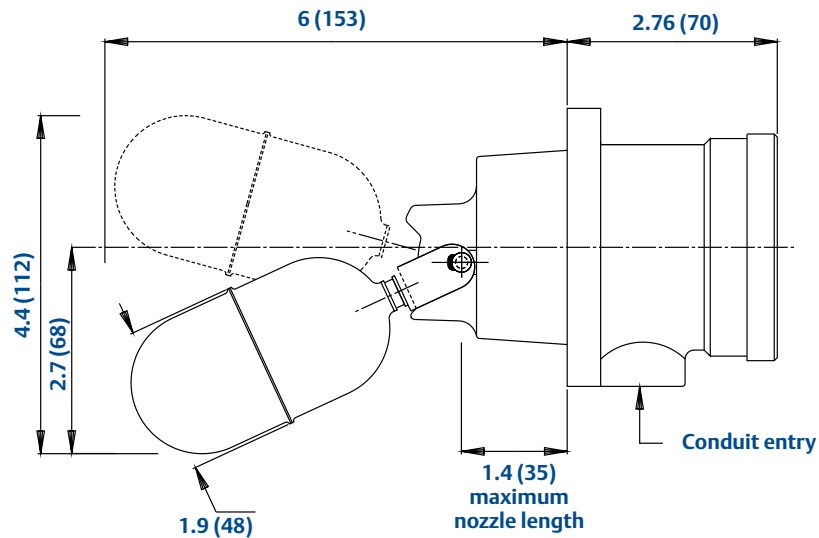

Mobrey 'A' and 'D' flange dimensions

Note: See Table 4 for dimensions.

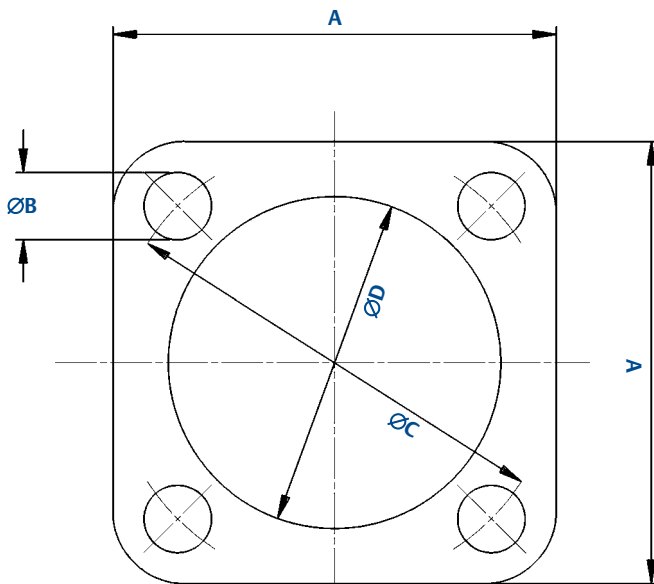

Table 4. Mobrey flange dimensions⁽¹⁾

Mobrey Flange	A	B	C	D ⁽²⁾
Mobrey 'A' Flange	3.6 (92)	0.55 (14)	3.6 (92)	2.6 (66)
Mobrey 'D' Flange	3.6 (92)	0.35 (9)	3.3 (83)	2.0 (50)

(1) Dimensions are in inches (mm)

(2) Mounting hole diameter D to be ± 0.4 in. (1 mm).

*The Emerson logo is a trademark and service mark of Emerson Electric Co.
Rosemount is a registered trademark of Rosemount Inc.
Mobrey is a registered trademark of Rosemount Measurement Ltd.
All other marks are the property of their respective owners.
Standard Terms and Conditions of Sale can be found at www.rosemount.com/terms_of_sale*

© 2015 Rosemount Measurement Limited. All rights reserved.

**Emerson Process Management
Rosemount Measurement Ltd.**
158 Edinbough Avenue,
Slough, Berks., SL1 4UE, UK
Tel +44 (0)1753 756600
Fax +44 (0)1753 823589
www.emersonprocess.com

**Emerson Process Management
Rosemount Inc.**
8200 Market Boulevard
Chanhassen, MN 55317, USA
Tel (USA) 1 800 999 9307
Tel (International) +1 952 906 8888
Fax +1 952 906 8889

mobrey

EMERSON™
Process Management