

Model 266HSH Gauge Model 266NSH Absolute

2600T Series Pressure Transmitters Engineered solutions for all applications



Base accuracy

- from 0.06 % of calibrated span (optional 0.04 %)

Reliable sensing system coupled with very latest digital technologies

- provides large turn down ratio up to 100:1

Comprehensive sensor choice

- optimize in-use total performance and stability

10-year stability

- 0.15 % of URL

Flexible configuration facilities

- provided locally via local LCD keypad

New TTG (Through-The-Glass) keypad technology

- allows quick and easy local configuration without opening the cover, even in explosion proof environments

IEC 61508 certification

- for SIL2 (1oo1) and SIL3 (1oo2) applications

Full compliance with PED Category III

Model 266HSH Gauge

Model 266NSH Absolute

Functional Specifications

Range and span limits

Sensor Code	Upper Range Limit (URL)	Lower Range Limit (LRL)	Minimum span	
			266HSH (Δ)	266NSH
E	16 kPa 160 mbar 64 inH2O	-16 kPa -160 mbar -64 inH2O	0.54 kPa 5.4 mbar 2.16 inH2O	
G	65 kPa 650 mbar 260 inH2O	-65 kPa -650 mbar -260 inH2O	0.65 kPa 6.5 mbar 2.6 inH2O	1.1 kPa 11 mbar 8 mmHg
H	160 kPa 1600 mbar 642 inH2O	0.07 kPa abs (§) 0.7 mbar abs (§) 0.5 mmHg (§)	1.6 kPa 16 mbar 6.4 inH2O	2.67 kPa 26.7 mbar 20 mmHg
M	600 kPa 6 bar 87 psi	0.07 kPa abs (§) 0.7 mbar abs (§) 0.5 mmHg (§)	6 kPa 0.06 bar 0.87 psi	10 kPa 0.1 bar 1.45 psi
P	2400 kPa 24 bar 348 psi	0.07 kPa abs (§) 0.7 mbar abs (§) 0.5 mmHg (§)	24 kPa 0.24 bar 3.5 psi	40 kPa 0.4 bar 5.8 psi
Q	8000 kPa 80 bar 1160 psi	0.07 kPa abs (§) 0.7 mbar abs (§) 0.5 mmHg (§)	80 kPa 0.8 bar 11.6 psi	134 kPa 1.34 bar 19.4 psi
S	16000 kPa 160 bar 2320 psi	0.07 kPa abs (§) 0.7 mbar abs (§) 0.5 mmHg (§)	160 kPa 1.6 bar 23.2 psi	267 kPa 2.67 bar 38.7 psi
V	60000 kPa 600 bar 8700 psi	0.07 kPa abs (§) 0.7 mbar abs (§) 0.5 mmHg (§)	600 kPa 6 bar 87 psi	
Z	105000 kPa 1050 bar 15225 psi	0.07 kPa abs (§) 0.7 mbar abs (§) 0.5 mmHg (§)	10500 kPa 105 bar 1522 psi	

(Δ) Lower Range Limit (LRL) for 266NSH is 0.07kPa abs, 0.7mbar abs, 0.5mmHg for all ranges.

(§) Lower Range Limit is 0.135 kPa abs, 1.35 mbar abs, 1 mmHg for inert Galden or 0.4 kPa abs, 4 mbar abs, 3 mmHg for inert Halocarbon.

Span limits

Maximum span = URL

IT IS RECOMMENDED TO SELECT THE TRANSMITTER SENSOR CODE PROVIDING THE TURNDOWN VALUE AS LOWEST AS POSSIBLE TO OPTIMIZE PERFORMANCE CHARACTERISTICS.

Zero suppression and elevation

Zero and span can be adjusted to any value within the range limits detailed in the table as long as:

– calibrated span ≥ minimum span

Damping

Selectable time constant : between 0 and 60 s

This is in addition to sensor response time.

Turn on time

Operation within specification in less than 10 s with minimum damping.

Insulation resistance

> 100 MΩ at 500 V DC (terminals to earth)

Operative limits

Pressure limits:

Overpressure limits

Without damage to the transmitter

Sensors	Fill fluid	Overpressure limits
Sensor E to M	Silicone oil	0.07 kPa abs, 0.7 mbar abs, 0.5 mmHg and 14 MPa, 140 bar, 2030 psi
Sensor P to S	Silicone oil	0.07 kPa abs, 0.7 mbar abs, 0.5 mmHg and 21 MPa, 210 bar, 3045 psi
Sensor V	Silicone oil	0.07 kPa abs, 0.7 mbar abs, 0.5 mmHg and 90 MPa, 900 bar, 13050 psi
Sensor E to M	Inert (Galden)	0.135 kPa abs, 1.35 mbar abs, 1 mmHg and 14 MPa, 140 bar, 2030 psi
Sensor P to S	Inert (Galden)	0.135 kPa abs, 1.35 mbar abs, 1 mmHg and 21 MPa, 210 bar, 3045 psi
Sensor E to M	Inert (Halocarbon)	0.4 kPa abs, 4 mbar abs, 3 mmHg and 14 MPa, 140 bar, 2030 psi ⁽¹⁾
Sensor P to S	Inert (Halocarbon)	0.4 kPa abs, 4 mbar abs, 3 mmHg and 21 MPa, 210 bar, 3045 psi
Sensor V	Inert (Galden)	40 kPa abs, 400 mbar abs, 5.8 psia and 90 MPa, 900 bar, 13050 psi

Sensors	Connection	Overpressure limits
Sensor Z	F250C	0.07 kPa abs, 0.7 mbar abs, 0.5 mmHg and 157.5 MPa, 1575 bar, 22837 psi
Sensor Z	1/4 - 18 NPT	0.07 kPa abs, 0.7 mbar abs, 0.5 mmHg and 135 MPa, 1350 bar, 19570 psi

Proof pressure

The transmitter can be exposed without leaking to line pressure of up to the following values:

Sensors	Proof pressure
Sensor E, G, H, M	28 MPa, 280 bar, 4060 psi
Sensor P, Q, S	40.25 MPa, 402.5 bar, 5836 psi
Sensor V	90 MPa, 900 bar, 13050 psi
Sensor Z 1/4 - 18 NPT connection	210.5 MPa, 2105 bar, 30522 psi
Sensor Z F250C connection	239,7 MPa, 2397 bar, 34763 psi

Meet ANSI/ISA-S 82.03 hydrostatic test requirements.

Temperature limits °C (°F) :

Ambient

is the operating temperature

Models 266HSH - 266NSH	Ambient temperature limits
Silicone oil for sensor E to V	-40 and 85 °C (-40 and 185 °F)
Inert (Galden) for sensor E to S	-20 and 85 °C (-4 and 185 °F)
Inert (Halocarbon) for sensor E to S	-20 and 85 °C (-4 and 185 °F)
Inert (Galden) for sensor V	-40 and 85 °C (-40 and 185 °F)
Sensor Z without filling	-40 and 85 °C (-40 and 185 °F)

IMPORTANT

For Hazardous Atmosphere applications see the temperature range specified on the certificate/approval relevant to the aimed type of protection

Models 266HSH - 266NSH	Ambient temperature limits
LCD integral display	-40 and 85 °C (-40 and 185 °F)

LCD display may not be clearly readable below -20 °C (-4 °F) or above +70 °C (+158 °F)

Process

Models 266HSH - 266NSH	Process temperature limits
Silicone oil for sensor E to V	-40 and 121 °C (-40 and 250 °F) ⁽¹⁾
Inert (Galden) for sensor E to S	-20 and 100 °C (-4 and 212 °F) ⁽²⁾
Inert (Halocarbon) for sensor E to S	-20 and 100 °C (-4 and 212 °F) ⁽²⁾
Inert (Galden) for sensor V	-40 and 121 °C (-40 and 250 °F)
Sensor Z without filling	-40 and 121 °C (-40 and 250 °F)

(1) 100 °C (212 °F) for application below atmospheric pressure

(2) 65 °C (150 °F) for application below atmospheric pressure

Storage

Models 266HSH - 266NSH	Storage temperature limits
Storage limits	-50 and 85 °C (-58 and 185 °F)
LCD integral display	-40 and 85 °C (-40 and 185 °F)

Model 266HSH Gauge

Model 266NSH Absolute

Environmental limits

Electromagnetic compatibility (EMC)

Comply with EN 61326 and NAMUR NE-21
Surge immunity level (with surge protector): 4 kV
(according to IEC 1000-4-5 EN 61000-4-5)

Pressure equipment directive (PED)

Comply with 97/23/EEC Category III Module H.

Humidity

Relative humidity: up to 100 %
Condensing, icing: admissible

Vibration resistance

Accelerations up to 2 g at frequency up to 1000 Hz
(according to IEC 60068-2-6)

Shock resistance

Acceleration: 50 g
Duration: 11 ms
(according to IEC 60068-2-27)

Wet and dust-laden atmospheres

The transmitter is dust and sand tight and protected against immersion effects as defined by EN 60529 (1989) to IP 67 (IP 68 on request) or by NEMA to 4X or by JIS to C0920. IP65 with Harting Han connector.

Hazardous atmospheres

With or without integral display

INTRINSIC SAFETY:

ATEX Europe (code E1) approval
II 1 G Ex ia IIC T6/T5/T4 and II 1/2 G Ex ia IIC T6/T5/T4 and
II 1 D Ex iaD 20 T85 °C and II 1/2 D Ex iaD 21 T85 °C; IP67.
IECEx (code E8) approval
Ex ia IIC T6/T5/T4 and Ex iaD 20 T85 °C and Ex iaD 21 T85 °C; IP67.
NEPSI China (code EY)
Ex ia IIC T4~T6, DIP A20TA, T4~T6.

EXPLOSION PROOF:

ATEX Europe (code E2) approval
II 1/2 G Ex d IIC T6 and II 1/2 D Ex tD A21 IP67 T85 °C (Ta = -50 to +75 °C).
IECEx (code E9) approval
Ex d IIC T6 and Ex tD A21 IP67 T85 °C (Ta = -50 to +75 °C).
NEPSI China (code EZ)
Ex d IIC T6, DIP A21TA, T6.

TYPE "N":

ATEX Europe (code E3) type examination
II 3 G Ex nL IIC T6/T5/T4 and II 3 D Ex tD A22 IP67 T85 °C; IP67.
IECEx (code ER) type examination
Ex nL IIC T6/T5/T4; IP67.
NEPSI China (code ES) type examination
Ex nL IIC T4~T6, DIP A22TA, T6.

FM Approvals US (code E6) and FM Approvals Canada (code E4):

- Explosionproof (US): Class I, Div. 1, Groups A, B, C, D
- Explosionproof (Canada): Class I, Div. 1, Groups B, C, D
- Dust ignitionproof : Class II, Div. 1, Groups E, F, G
- Suitable for: Class II, Div. 2, Groups F, G; Class III, Div.1, 2
- Nonincendive: Class I, Div. 2, Groups A, B, C, D
- Intrinsically safe: Class I, II, III, Div. 1, Groups A, B, C, D, E, F, G
 - Class I, Zone 0 AEx ia IIC T6/T4, Zone 0 (FM US)
 - Class I, Zone 0 Ex ia IIC T6/T4, Zone 0 (FM Canada)

COMBINED ATEX (code EW = E1 + E2 + E3), (code E7 = E1 + E2)

COMBINED ATEX and FM Approvals (code EN = EW + E4 + E6)

COMBINED FM Approvals US and Canada

- Intrinsically safe (code EA)
- Explosionproof (code EB)
- Nonincendive (code EC)

COMBINED IEC (code EH = E8 + E9), (code EI = E8 + E9 + ER)

COMBINED NEPSI (code EP = EY + EZ), (code EQ = EY + EZ + ES)

GOST (Russia), GOST (Kazakhstan), GOST (Belarus), Inmetro (Brazil)
based on ATEX

REFER TO CERTIFICATES FOR AMBIENT TEMPERATURE RANGES (WITHIN THE LIMITS OF -50 TO 85°C) RELATED TO THE DIFFERENT TEMPERATURE CLASSES

Electrical Characteristics and Options

HART digital communication and 4 to 20 mA output Power Supply

The transmitter operates from 10.5 to 42 V DC with no load and is protected against reverse polarity connection (additional load allows operations over 42 V DC).

For Ex ia and other intrinsically safe approval power supply must not exceed 30 V DC.

Minimum operating voltage increase to 12.3 V DC with optional surge protector

Ripple

20 mV max on a 250 Ω load as per HART specifications.

Load limitations

4 to 20 mA and HART total loop resistance :

$$R \text{ (k}\Omega\text{)} = \frac{\text{Supply voltage} - \text{min. operating voltage (V DC)}}{22 \text{ mA}}$$

A minimum of 250 Ω is required for HART communication.

Optional indicators

Integral display (code L1)

Wide screen LCD, 128 x 64 pixel,

52.5 x 27.2 mm (2.06 x 1.07 in.) dot matrix. Multilanguage.

Four keys for configuration and management of device.

Easy setup for quick commissioning.

User selectable application-specific visualizations.

Totalized and instantaneous flow indication.

Display may also indicate static pressure, sensor temperature and diagnostic messages and provides configuration facilities.

Through-the-glass (TTG) controlled display (code L5)

As above integral display but equipped with the innovative TTG keypad allowing the activation of the configuration and management menus of the device without the need of removing the transmitter housing cover.

TTG keypad is protected against accidental activations.

Optional surge protection

Up to 4kV

– voltage 1.2 μ s rise time / 50 μ s delay time to half value

– current 8 μ s rise time / 20 μ s delay time to half value

Output signal

Two-wire 4 to 20 mA, user-selectable for linear or 22 points linearization table (i.e. for horizontal or spherical tank level measurement).

HART® communication provides digital process variable superimposed on 4 to 20 mA signal, with protocol based on Bell 202 FSK standard.

Output current limits (to NAMUR standard)

Overload condition

- Lower limit: 3.8 mA (configurable from 3.8 to 4 mA)

- Upper limit: 20.5 mA (configurable from 20 to 21 mA)

Alarm current

- Lower limit: 3.6 mA (configurable from 3.6 to 4 mA)

- Upper limit: 21 mA (configurable from 20 to 22 mA)

Factory setting: high alarm current

Process diagnostics (PILD)

Plugged impulse line detection (PILD) generates a warning via HART communication. The device can also be configured to drive the analog output signal to the "Alarm current".



Model 266HSH Gauge

Model 266NSH Absolute

FOUNDATION Fieldbus output

Device type

LINK MASTER DEVICE

Link Active Scheduler (LAS) capability implemented.

Manufacturer code: 000320 (hex)

Device type code: 0007 (hex)

Power supply

The transmitter operates from 9 to 32 V DC, polarity independent, with or without surge protector.

For Ex ia approval power supply must not exceed 24 V DC (entity certification) or 17.5 V DC (FISCO certification), according to FF-816.

Current consumption

operating (quiescent): 15 mA

fault current limiting: 20 mA max.

Output signal

Physical layer in compliance to IEC 1158-2/EN 61158-2 with transmission to Manchester II modulation, at 31.25 kbit/s.

Function blocks/execution period

3 enhanced Analog Input blocks/25 ms max (each)

1 enhanced PID block/40 ms max.

1 standard ARithmetic block/25 ms

1 standard Input Selector block/25 ms

1 standard Control Selector block/25 ms

1 standard Signal Characterization block/25 ms

1 standard Integrator/Totalizer block/25 ms

Additional blocks

1 enhanced Resource block,

1 custom Pressure with calibration transducer block

1 custom Advanced Diagnostics transducer block including Plugged Input Line Detection

1 custom Local Display transducer block

Number of link objects

35

Number of VCRs

35

Output interface

FOUNDATION fieldbus digital communication protocol to standard H1, compliant to specification V. 1.7.

Integral display

Wide screen LCD, 128 x 64 pixel,

52.5 x 27.2 mm (2.06 x 1.07 in.) dot matrix. Multilanguage.

Four keys for configuration and management of device.

Easy setup for quick commissioning.

User selectable application-specific visualizations.

Totalized and instantaneous flow indication.

Display may also indicate static pressure, sensor temperature and diagnostic messages and provides configuration facilities.

Transmitter failure mode

The output signal is “frozen” to the last valid value on gross transmitter failure condition, detected by self-diagnostics which also indicate a BAD conditions. If electronic failure or short circuit occur the transmitter consumption is electronically limited at a defined value (20 mA approx), for safety of the network.

PROFIBUS PA output

Device type

Pressure transmitter compliant to Profiles 3.0.1
Identification number: 3450 (hex)

Power supply

The transmitter operates from 9 to 32 V DC , polarity independent, with or without surge protector.
For Ex ia approval power supply must not exceed 17.5 V DC.
Intrinsic safety installation according to FISCO model.

Current consumption

operating (quiescent): 15 mA
fault current limiting: 20 mA max.

Output signal

Physical layer in compliance to IEC 1158–2/EN 61158–2 with transmission to Manchester II modulation, at 31.25 kbit/s.

Output interface

PROFIBUS PA communication according to Profibus DP50170 Part 2/DIN 19245 part 1–3.

Output update time

25 ms

Data blocks

3 analog input, 1 physical.

Additional blocks

1 Pressure with calibration transducer block
1 Advanced Diagnostics transducer block including Plugged Input Line Detection
1 Local Display transducer block

Integral display

Wide screen LCD, 128 x 64 pixel,
52.5 x 27.2 mm (2.06 x 1.07 in.) dot matrix. Multilanguage.
Four keys for configuration and management of device.
Easy setup for quick commissioning.
User selectable application-specific visualizations.
Instantaneous flow indication.
Display may also indicate static pressure, sensor temperature and diagnostic messages and provides configuration facilities.

Transmitter failure mode

On gross transmitter failure condition, detected by self-diagnostics, the output signal can be driven to defined conditions, selectable by the user as safe, last valid or calculated value.
If electronic failure or short circuit occur the transmitter consumption is electronically limited at a defined value (20 mA approx), for safety of the network.

Performance specifications

Stated at reference condition to IEC 60770 ambient temperature of 20 °C (68 °F), relative humidity of 65 %, atmospheric pressure of 1013 hPa (1013 mbar), mounting position with vertical diaphragm and zero based range for transmitter with isolating diaphragms in AISI 316 L ss or Hastelloy and silicone oil fill and HART digital trim values equal to 4 mA and to 20 mA span end points, in linear mode. Unless otherwise specified, errors are quoted as % of span. Some performance referring to the Upper Range Limit are affected by the actual turndown (TD) as ratio between Upper Range Limit (URL) and calibrated span.

IT IS RECOMMENDED TO SELECT THE TRANSMITTER SENSOR CODE PROVIDING THE TURNDOWN VALUE AS LOWEST AS POSSIBLE TO OPTIMIZE PERFORMANCE CHARACTERISTICS.

Dynamic performance (according to IEC 61298–1 definition)

Sensors	Time constant (63.2 % of total step change)
Sensor M to S	≤ 70 ms
Sensor H	100 ms
Sensor G	130 ms
Sensor V	150 ms
Sensor Z	≤ 80 ms
Dead time for all sensors	30 ms

Response time (total) = dead time + time constant

Accuracy rating

% of calibrated span, including combined effects of terminal based linearity, hysteresis and repeatability.
For fieldbus versions SPAN refer to analog input function block outscale range

Model	Sensor	for TD up to	
266HSH	G to Q	from 1:1 to 10:1	± 0.06 %
	G to Q	from 10:1 to 100:1	± (0.006 x TD) %
	S, V	from 1:1 to 10:1	± 0.075 %
	S, V	from 10:1 to 100:1	± (0.0075 x TD) %
	E	from 1:1 to 10:1	± 0.075 %
	E	from 10:1 to 30:1	± (0.0075 x TD) %
	Z	from 1:1 to 5:1	± 0.15 %
	Z	from 5:1 to 10:1	± (0.03 x TD) %
266HSH	G to Q	from 1:1 to 5:1	± 0.04 %
(option D2)	G to Q	from 5:1 to 100:1	± (0.0105 + 0.0059 x TD) %
266NSH	G to S	from 1:1 to 10:1	± 0.075 %
	G to S	from 10:1 to 60:1	± (0.0075 x TD) %

Model 266HSH Gauge

Model 266NSH Absolute

Ambient temperature

per 20K change between the limits of -40 °C to +85 °C
(per 36 °F change between the limits of -40 to +185 °F):

Model	Sensor	for TD up to	
266HSH	G to Q	10:1	± (0.03 % URL + 0.045 % span)
	E, S and V	10:1	± (0.04 % URL + 0.065 % span)
	Z	10:1	± (0.06 % URL + 0.10 % span)
266NSH	G to Q	10:1	± (0.06 % URL + 0.09 % span)
	S	10:1	± (0.08 % URL + 0.13 % span)

for an ambient temperature change from -10 °C to +60 °C
(+14 to +140 °F):

Model	Sensor	for TD up to	
266HSH	G to Q	10:1	± (0.055 % URL + 0.08 % span)
	E, S and V	10:1	± (0.075 % URL + 0.11 % span)
	Z	10:1	± (0.10 % URL + 0.15 % span)
266NSH	G to Q	10:1	± (0.11 % URL + 0.16 % span)
	S	10:1	± (0.15 % URL + 0.22 % span)

per 10K change between the limits of -40 °C to -10 °C or
+60° to +85 °C (per 18 °F change between the limits of -40
to +14 °F or +140° to +185 °F):

Model	Sensor	for TD up to	
266HSH	G to Q	10:1	± (0.03 % URL + 0.04 % span)
	E, S and V	10:1	± (0.04 % URL + 0.055 % span)
	Z	10:1	± (0.06 % URL + 0.10 % span)
266NSH	G to Q	10:1	± (0.055 % URL + 0.08 % span)
	S	10:1	± (0.075 % URL + 0.11 % span)

Supply voltage

Within voltage/load specified limits the total effect is less than
0.005 % of URL per volt.

Load

Within load/voltage specified limits the total effect is negligible.

Electromagnetic field

Meets all the requirements of EN 61326 and NAMUR NE-21.

Common mode interference

No effect from 100Vrms @ 50Hz, or 50 V DC

Supply voltage

Within voltage/load specified limits the total effect is less than
0.005 % of URL per volt.

Load

Within load/voltage specified limits the total effect is negligible.

Electromagnetic field

Meets all the requirements of EN 61326 and NAMUR NE-21.

Common mode interference

No effect from 100Vrms @ 50Hz, or 50 V DC

Mounting position

No effect for rotation on diaphragm plane. A tilt up to 90° from
vertical causes a zero shifts up to 0.5 kPa, 5 mbar or 2 inH2O,
which can be corrected with zero adjustment. No span effect.

Stability

±0.15 % of URL over a ten years period for sensors E to V
±0.45 % of URL over a three years period for sensor Z

Total performance

similar to DIN 16086

Temperature change in the range from -10 to 60 °C (14 to 140 °F)

Model	Sensor	for TD up to	
266HSH	G to Q	1:1	± 0.15 % of calibrated span
266NSH	G to Q	1:1	± 0.28 % of calibrated span

Total performance includes the measurement deviation of
- non-linearity including hysteresis and non-reproducibility,
- thermal change of ambient temperature on zero and span

$$E_{\text{perf}} = \sqrt{(E_{\Delta Tz} + E_{\Delta Ts})^2 + E_{\text{lin}}^2}$$

E_{perf} = Total Performance

$E_{\Delta Tz}$ = Effect of the ambient temperature on zero

$E_{\Delta Ts}$ = Effect of the ambient temperature on span

E_{lin} = Accuracy rating (for terminal-based linearity 0.06 % or
0.075% as per sensor accuracy)

Physical Specification

(Refer to ordering information sheets for variant availability related to specific model or versions code)

Materials

Process isolating diaphragms (*)

AISI 316 L ss; AISI 316 L ss gold plated;
Monel 400™; Tantalum; Hastelloy C-276™;
Hastelloy C276™ gold plated (sensors G to V).
Inconel 718 (sensor Z).

Process connection (*)

AISI 316 L ss; Hastelloy C-276™; Monel 400™ (sensor G to V).
Inconel 718 (sensor Z)

Sensor fill fluid

Silicone oil; Inert fill (Halocarbon™ 4.2 or Galden™).

Mounting bracket (**)

Zinc plated carbon steel with chrome passivation; AISI 316 L ss.

Sensor housing

AISI 316 L ss.

Electronic housing and covers

Aluminium alloy (copper content ≤ 0.3 %) with baked epoxy finish (colour RAL9002);

AISI 316 L ss.

Covers O-ring

Buna N.

Local adjustments (zero, span and write protect)

Glass filled polyphenylene oxide (removable).

Plates

AISI 316ss for transmitter nameplate, certification plate, optional tag/calibration plate attached to the electronics housing and optional wired-on customer data plate. All printing by laser.

Calibration

Standard: at maximum span, zero based range, ambient temperature and pressure;

Optional: at specified range and ambient conditions.

(*) Wetted parts of the transmitter.

(**) U-bolt material: high-strength alloy steel or AISI 316 L ss;
bolts/nuts material: high-strength alloy steel or AISI 316 ss.

Model 266HSH Gauge

Model 266NSH Absolute

Optional extras

Mounting brackets

For 60mm. (2in) pipes or wall mounting.

Display

4-position (at 90°) user orientable.

Optional plates

Code I2: for tag (up to 31 characters) and calibration details (up to 31 characters: lower and upper values plus unit) fixed onto transmitter housing.

Code I1: for customer data (32 character x 4 lines) wired-on transmitter housing

Surge protection

Cleaning procedure for oxygen service

Test Certificates (test, design, calibration, material traceability)

Tag and manual language

Communication connectors

Process connections

For sensors G to S

$\frac{1}{2}$ – 14 NPT male or female; DIN EN837-1 G $\frac{1}{2}$ B; adapter straight (180°) entry; adapter angle (90°) entry.

For sensor V

$\frac{1}{2}$ – 14 NPT male or female; DIN EN837-1 G $\frac{1}{2}$ B.

For sensor Z

$\frac{1}{4}$ – 18 NPT female; F250C (autoclave).

Electrical connections

Two $\frac{1}{2}$ – 14 NPT or M20x1.5 threaded conduit entries, direct on housing.

Special communication connector (on request)

– HART : straight or angle Harting Han 8D connector and one plug.

– FOUNDATION Fieldbus, PROFIBUS PA: M12x1 or 7/8 in.

Terminal block

HART version: three terminals for signal/external meter wiring up to 2.5 mm² (14 AWG), also connection points for test and communication purposes.

Fieldbus versions: two terminals for signal wiring (bus connection) up to 2.5 mm² (14 AWG)

Grounding

Internal and external 6 mm² (10 AWG) ground termination points are provided.

Mounting position

Transmitter can be mounted in any position.

Electronics housing may be rotated to any position. A positive stop prevents over travel.

Mass (without options)

2.1 kg approx (4.6 lb); add 1.5 kg (3.3 lb) for AISI housing.

Add 650 g (1.5 lb) for packing.

Packing

Carton 27 x 24 x 20 cm approx (11 x 10 x 8 in.).

Configuration

Transmitter with HART communication and 4 to 20 mA Standard configuration

Transmitters are factory calibrated to customer's specified range. Calibrated range and tag number are stamped on the tag plate. If a calibration range and tag data are not specified, the transmitter will be supplied with the plate left blank and configured as follows:

Engineering Unit	kPa
4 mA	Zero
20 mA	Upper Range Limit (URL)
Output	Linear
Damping	1 s
Transmitter failure mode	Upscale
Software tag (8 characters max)	Blank
Optional LCD display	PV in kPa; output in mA and in percentage on bargraph

Any or all the above configurable parameters, including Lower range-value and Upper range-value which must be the same unit of measure, can be easily changed using the HART hand-held communicator or by a PC running the configuration software with DTM for 266 models. The transmitter database is customized with specified flange type and material, O-ring and drain/vent materials and meter code option.

Custom configuration (option N6)

The following data may be specified in addition to the standard configuration parameters:

Descriptor	16 alphanumeric characters
Message	32 alphanumeric characters
Date	Day, month, year

For HART protocol available engineering units of pressure measure are :

Pa, kPa, MPa

inH₂O@4 °C, mmH₂O@4 °C, psi

inH₂O@20 °C, ftH₂O@20 °C, mmH₂O@20 °C

inHg, mmHg, Torr

g/cm², kg/cm², atm

mbar, bar

These and others are available for PROFIBUS and FOUNDATION Fieldbus.

Transmitter with PROFIBUS PA communication Standard configuration

Transmitters are factory calibrated to customer's specified range. Calibrated range and tag number are stamped on the tag plate. If a calibration range and tag data are not specified, the transmitter will be supplied with the plate left blank and configured as follows:

Measure Profile	Pressure
Engineering Unit	kPa
Output scale 0 %	Lower Range Limit (LRL)
Output scale 100 %	Upper Range Limit (URL)
Output	Linear
Hi-Hi Limit	Upper Range Limit (URL)
Hi Limit	Upper Range Limit (URL)
Low Limit	Lower Range Limit (LRL)
Low-Low Limit	Lower Range Limit (LRL)
Limits hysteresis	0.5 % of output scale
PV filter	0 s
Address (set by local key)	126
Tag	32 alphanumeric characters
Optional LCD display	PV in kPa; output in percentage on bargraph

Any or all the above configurable parameters, including the range values which must be the same unit of measure, can be easily changed by a PC running the configuration software with DTM for 266 models. The transmitter database is customized with specified flange type and material, O-ring and drain/vent materials and meter code option.

Custom configuration (option N6)

The following data may be specified in addition to the standard configuration parameters:

Descriptor	32 alphanumeric characters
Message	32 alphanumeric characters
Date	Day, month, year

Model 266HSH Gauge

Model 266NSH Absolute

Transmitter with FOUNDATION Fieldbus communication

Standard configuration

Transmitters are factory calibrated to customer's specified range. Calibrated range and tag number are stamped on the tag plate. If a calibration range and tag data are not specified, the transmitter will be supplied with the plate left blank and the analog input function block FB1 is configured as follows:

Measure Profile	Pressure
Engineering Unit	kPa
Output scale 0 %	Lower Range Limit (LRL)
Output scale 100 %	Upper Range Limit (URL)
Output	Linear
Hi-Hi Limit	Upper Range Limit (URL)
Hi Limit :	Upper Range Limit (URL)
Low Limit	Lower Range Limit (LRL)
Low-Low Limit	Lower Range Limit (LRL)
Limits hysteresis	0.5 % of output scale
PV filter time	0 s
Tag	32 alphanumeric characters
Optional LCD display	PV in kPa; output in percentage on bargraph

The analog input function block FB2 and FB3 are configured respectively for the sensor temperature measured in °C and for the static pressure measured in MPa.

Any or all the above configurable parameters, including the range values, can be changed using any host compliant to FOUNDATION fieldbus. The transmitter database is customized with specified flange type and material, O-ring and drain/vent materials and meter code option.

Custom configuration (option N6)

The following data may be specified in addition to the standard configuration parameters:

Descriptor	32 alphanumeric characters
Message	32 alphanumeric characters
Date	Day, month, year

MOUNTING DIMENSIONS (not for construction unless certified) – dimensions in mm (in.)

Transmitter with barrel housing - 1/2 NPT female connection for sensor E to S

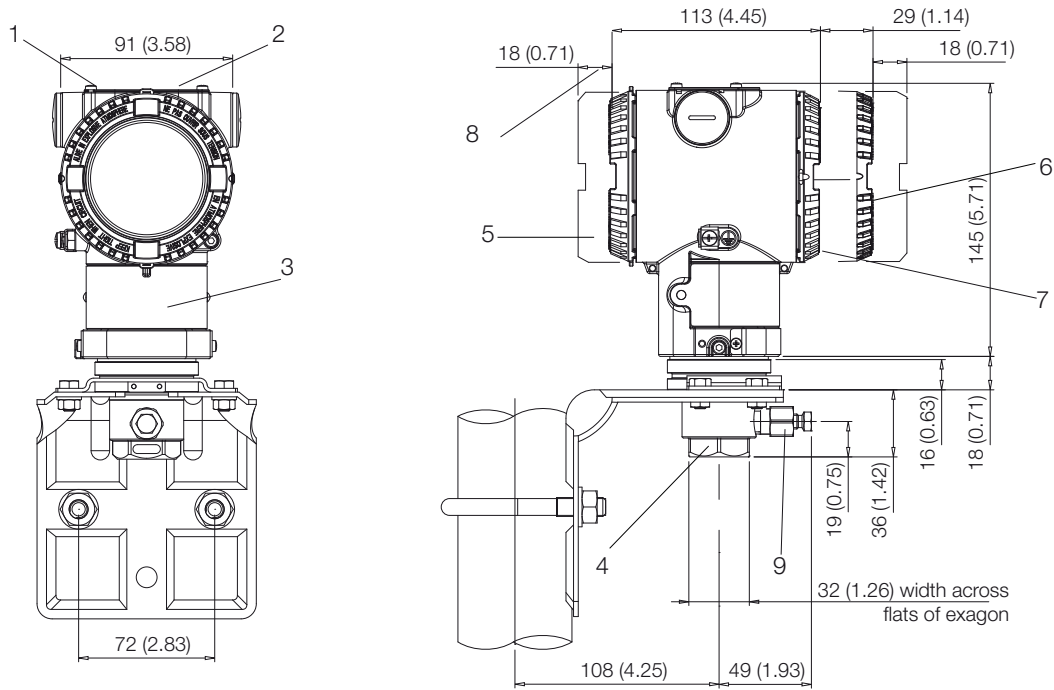

1 Adjustments | 2 Identification plate | 3 Certification plate | 4 Process connection | 5 Terminal side | 6 Integral display housing | 7 Electronic side | 8 Space for cover removal | 9 Drain/vent valve

Transmitter with barrel housing - 1/2 NPT female connection for sensor V

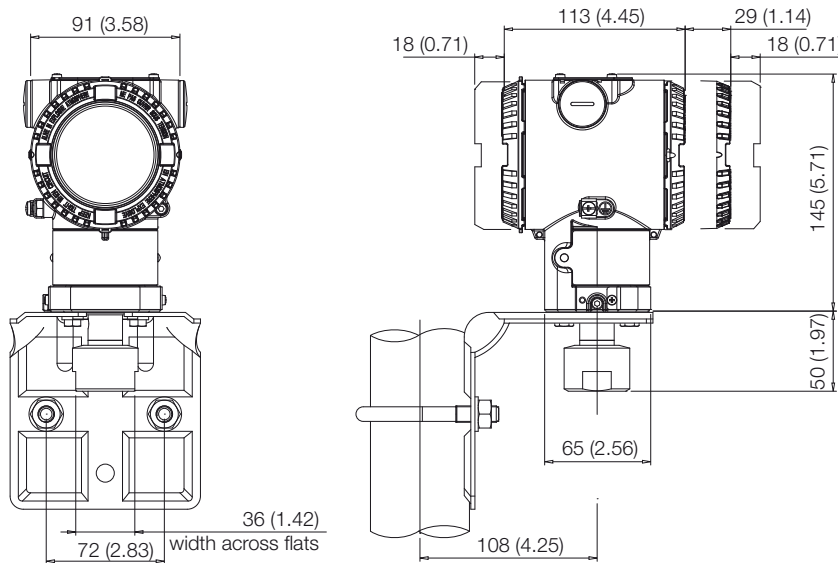

Model 266HSH Gauge Model 266NSH Absolute

Transmitter with barrel housing - F250C female connection for sensor Z

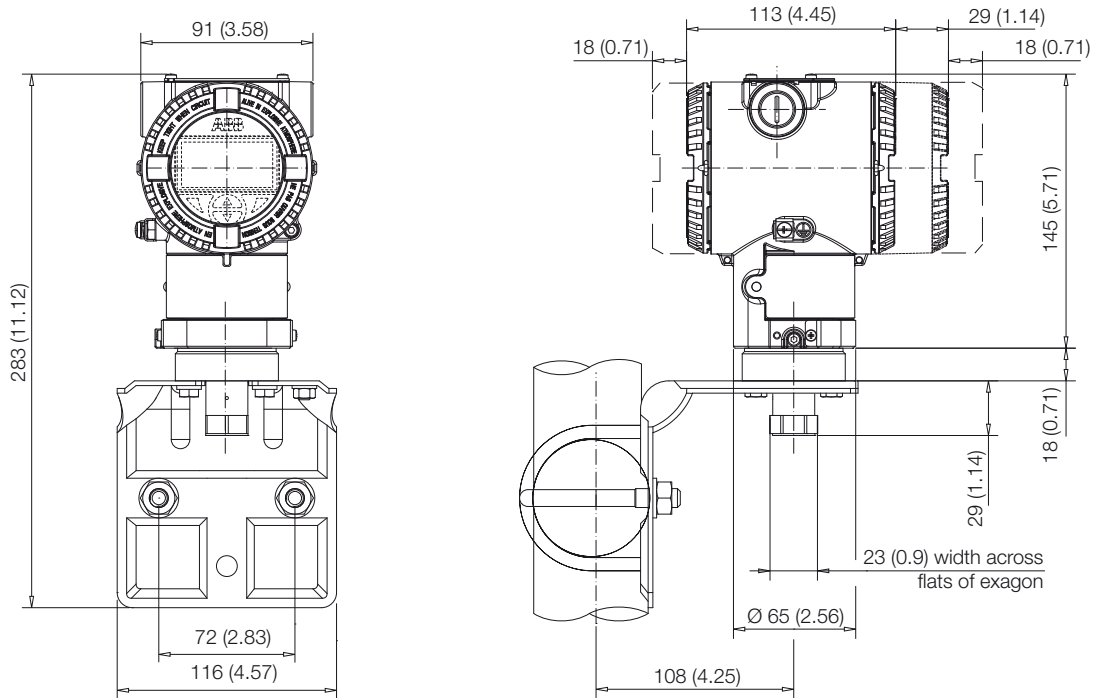

Transmitter with barrel housing - 1/4 NPT female connection for sensor Z

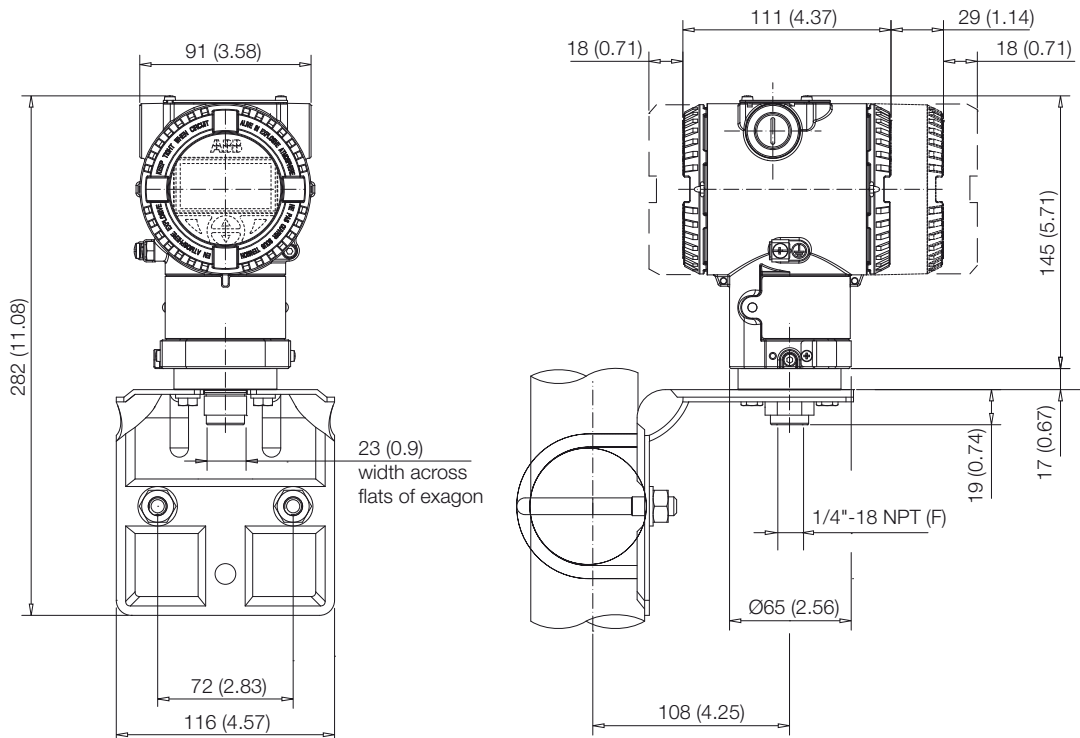

Transmitter with DIN aluminium housing - 1/2 NPT male connection for sensor E to S

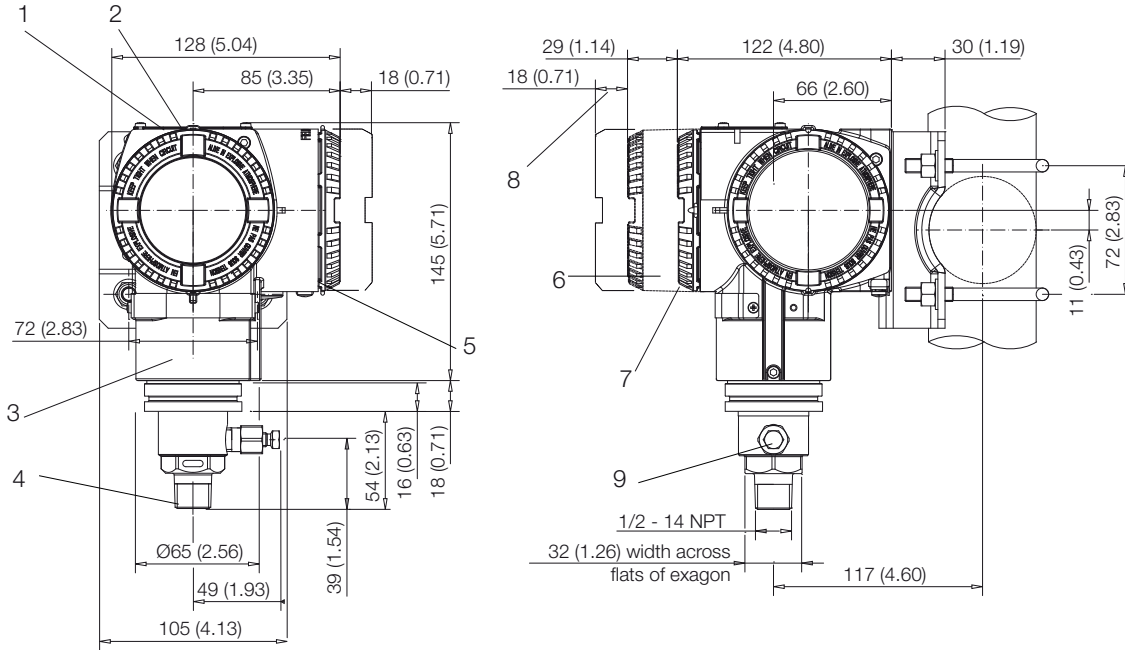

1 Adjustments | 2 Identification plate | 3 Certification plate | 4 Process connection | 5 Terminal side | 6 Integral display housing | 7 Electronic side | 8 Space for cover removal | 9 Drain/vent valve

Transmitter with DIN aluminium housing - 1/2 NPT male connection for sensor V

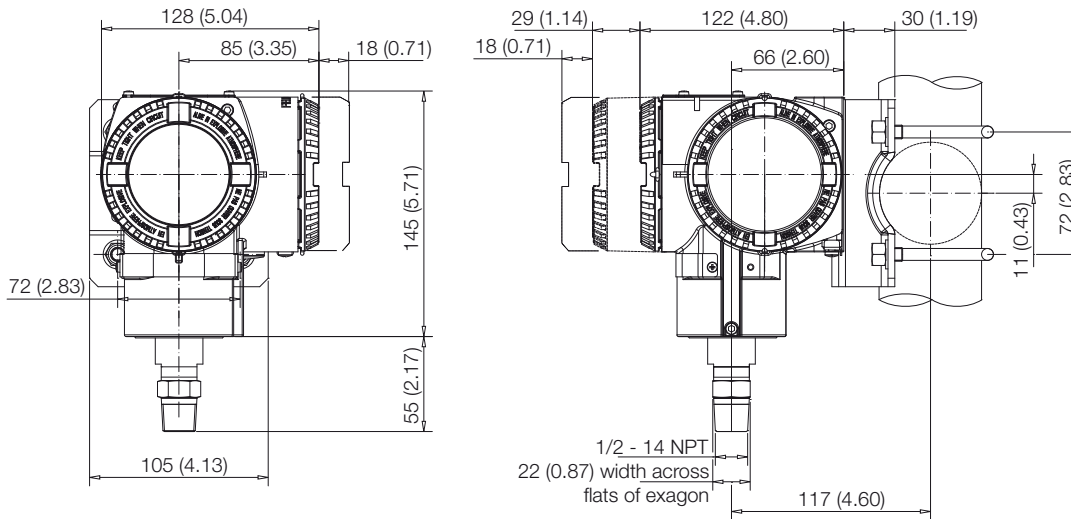

Model 266HSH Gauge Model 266NSH Absolute

Transmitter with barrel housing - DIN-EN837-1 G 1/2 B connection for sensor E to S

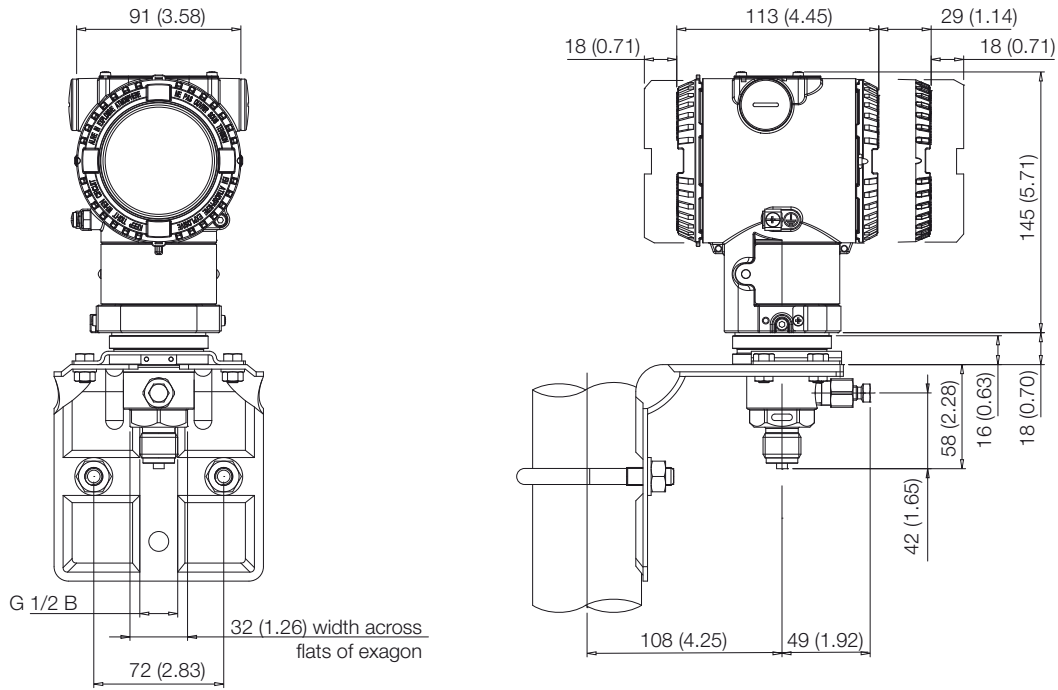

Transmitter with barrel housing - DIN-EN837-1 G 1/2 B connection for sensor V

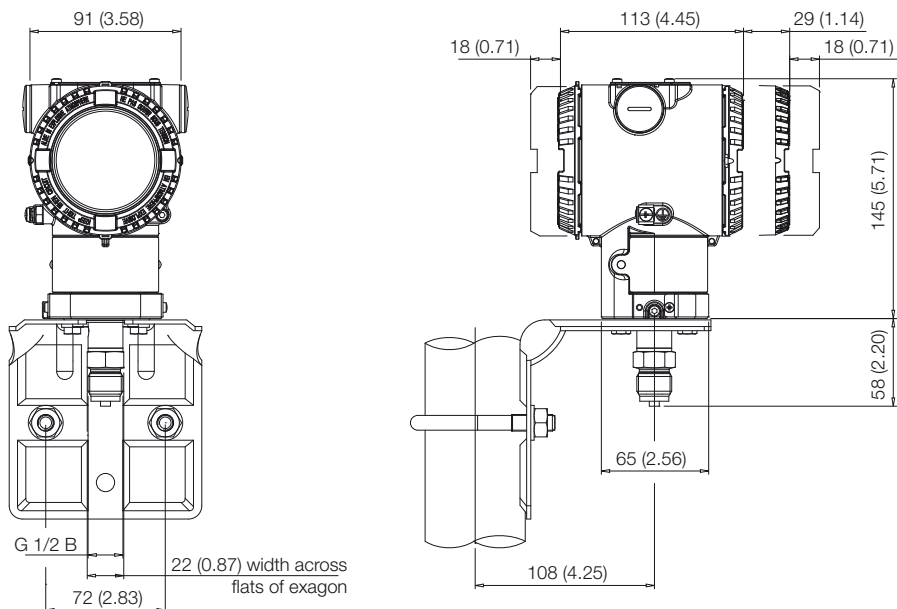

Transmitter with barrel housing - adapter straight (180°) entry connection for sensor E to S

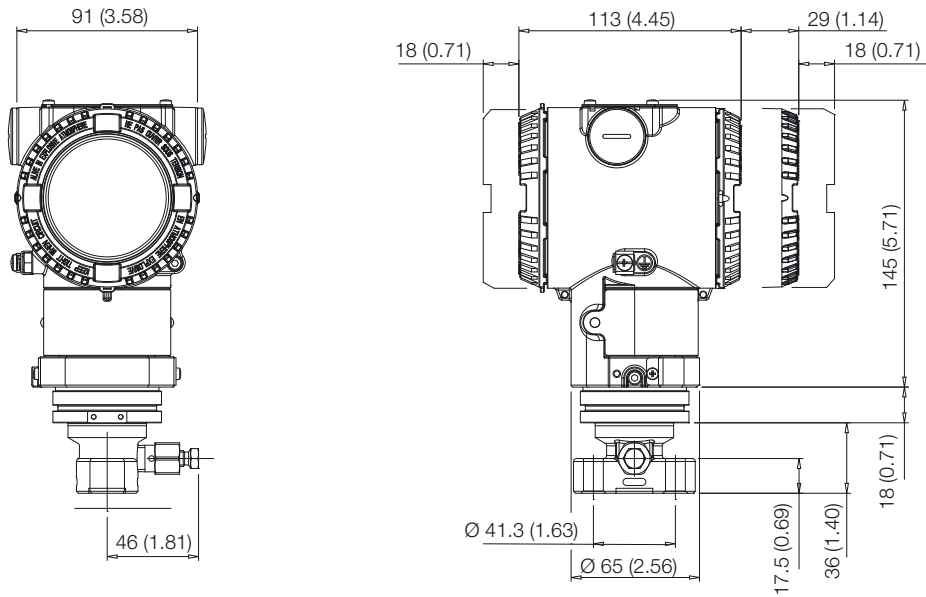

Transmitter with barrel housing - adapter angle (90°) entry connection for sensor E to S

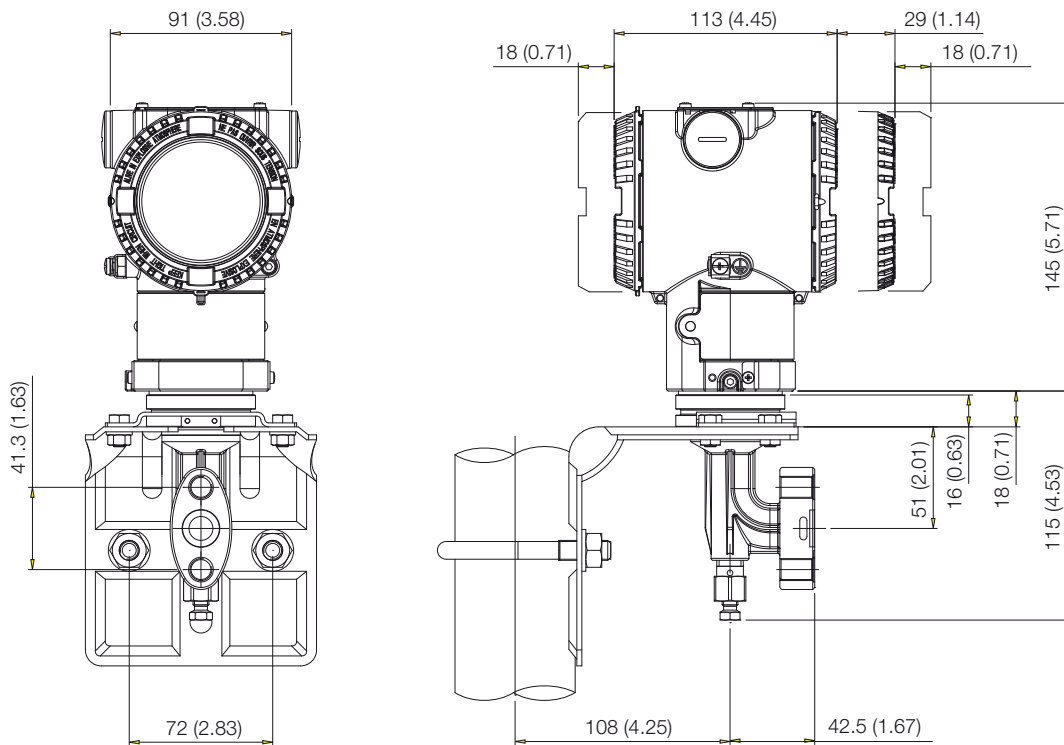

Model 266HSH Gauge Model 266NSH Absolute

Electrical connections

HART Version

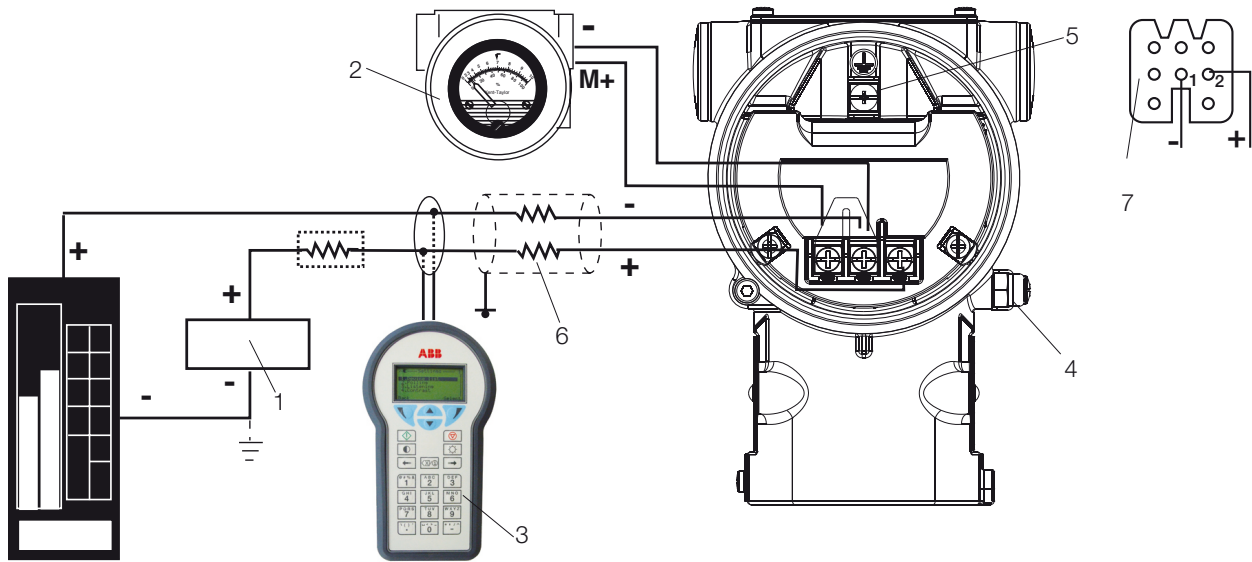

HART hand-held communicator may be connected at any wiring termination point in the loop, providing the minimum resistance is 250 ohm. If this is less than 250 ohm, additional resistance should be added to allow communications. Maximum voltage drop on external remote indicator is 0.7 Vdc

FIELDBUS Versions

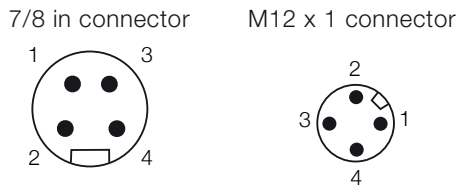

PIN (male) IDENTIFICATION		
	FOUNDATION Fieldbus	PROFIBUS PA
1	DATA -	DATA +
2	DATA +	GROUND
3	SHIELD	DATA -
4	GROUND	SHIELD

CONNECTOR IS SUPPLIED LOOSE
WITHOUT MATING FEMALE PLUG

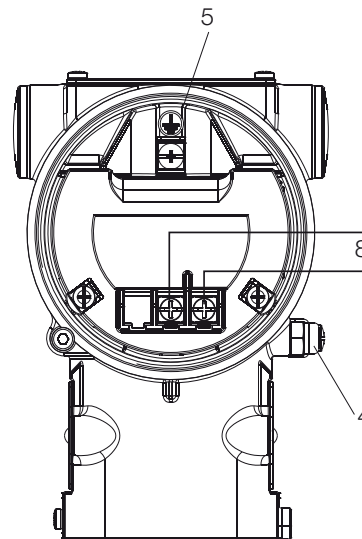

1 Power source | 2 Remote indicator | 3 Hand-held communicator | 4 External ground termination point | 5 Internal ground termination point | 6 Line load | 7 Harting Han 8D socket insert for mating plug (supplied loose) | 8 Fieldbus line (polarity independent)

BASIC ORDERING INFORMATION model 266HSH Gauge Pressure Transmitter

Select one character or set of characters from each category and specify complete catalog number.

Refer to additional ordering information and specify one or more codes for each transmitter if additional options are required.

BASE MODEL - 1 st to 6 th characters			2	6	H	S	H	X	X	X	X	X
Gauge Pressure Transmitter – BASE ACCURACY 0.06 %												
SENSOR - Span limits - 7 th character												continued see next page
0.54 and 16 kPa	5.4 and 160 mbar	2.16 and 64 inH2O						E				
0.65 and 65 kPa	6.5 and 650 mbar	2.6 and 260 inH2O						G				
1.6 and 160 kPa	16 and 1600 mbar	6.4 and 642 inH2O						H				
6 and 600 kPa	0.06 and 6 bar	0.87 and 87 psi						M				
24 and 2400 kPa	0.24 and 24 bar	3.5 and 348 psi						P				
80 and 8000 kPa	0.8 and 80 bar	11.6 and 1160 psi						Q				
160 and 16000 kPa	1.6 and 160 bar	23.2 and 2320 psi						S				
600 and 60000 kPa	6 and 600 bar	87 and 8700 psi						V				
10500 and 105000 kPa	105 and 1050 bar	1522 and 15225 psi						Z				
Diaphragm material / Fill fluid (wetted parts) - 8 th character												
AISI 316 L ss	Silicone oil		(Notes 2, 16)	NACE	S							
Hastelloy C-276™	Silicone oil		(Note 16)	NACE	K							
Hastelloy C-276™ gold plated	Silicone oil		(Notes 3, 16)	NACE	G							
Monel 400™	Silicone oil		(Notes 2, 16)	NACE	M							
AISI 316 L ss gold plated	Silicone oil		(Notes 2, 15, 16)	NACE	8							
Tantalum	Silicone oil		(Notes 2, 16)	NACE	T							
AISI 316 L ss	Inert fluid - Galden		(Notes 1, 2, 16)	NACE	A							
Hastelloy C-276™	Inert fluid - Galden		(Notes 1, 16)	NACE	F							
Hastelloy C-276™ gold plated	Inert fluid - Galden		(Notes 1, 3, 16)	NACE	E							
Monel 400™	Inert fluid - Galden		(Notes 1, 2, 16)	NACE	C							
AISI 316 L ss gold plated	Inert fluid - Galden		(Notes 1, 2, 15, 16)	NACE	9							
Tantalum	Inert fluid - Galden		(Notes 1, 2, 16)	NACE	D							
AISI 316 L ss	Inert fluid - Halocarbon		(Notes 1, 2, 16)	NACE	L							
Hastelloy C-276™	Inert fluid - Halocarbon		(Notes 1, 2, 16)	NACE	P							
Monel 400™	Inert fluid - Halocarbon		(Notes 1, 2, 16)	NACE	4							
AISI 316 L ss gold plated	Inert fluid - Halocarbon		(Notes 1, 2, 15, 16)	NACE	I							
Tantalum	Inert fluid - Halocarbon		(Notes 1, 2, 16)	NACE	5							
Inconel 718	No filling	(for sensor Z ONLY)	(Notes 2, 3)	NACE	N							

Model 266HSH Gauge Model 266NSH Absolute

BASIC ORDERING INFORMATION model 266HSH Gauge Pressure Transmitter					2	6	H	S	H	X	X	X
Process connection (wetted parts) - 9th character												
AISI 316 L ss	1/2 – 14 NPT-f female	(Notes 4, 16)	NACE	B								
AISI 316 L ss	1/2 – 14 NPT-f male	(Notes 4, 16)	NACE	T								
AISI 316 L ss	DIN EN837-1 G 1/2 B	(Notes 4, 16)	NACE	P								
AISI 316 L ss	Adapter straight (180°) entry (not available with bracket)	(Notes 2, 4, 16)	NACE	A								
AISI 316 L ss	Adapter angle (90°) entry	(Notes 2, 4, 16)	NACE	N								
Hastelloy C-276™	1/2 – 14 NPT-f female	(Notes 5, 16)	NACE	E								
Hastelloy C-276™	1/2 – 14 NPT-f male	(Notes 5, 16)	NACE	K								
Hastelloy C-276™	DIN EN837-1 G 1/2 B	(Notes 5, 16)	NACE	D								
Hastelloy C-276™	Adapter straight (180°) entry (not available with bracket)	(Notes 2, 5, 16)	NACE	F								
Hastelloy C-276™	Adapter angle (90°) entry	(Notes 2, 5, 16)	NACE	C								
Monel 400™	1/2 – 14 NPT-f female	(Notes 2, 6, 16)	NACE	1								
Monel 400™	1/2 – 14 NPT-f male	(Notes 2, 6, 16)	NACE	2								
Monel 400™	DIN EN837-1 G 1/2 B	(Notes 2, 6, 16)	NACE	3								
Inconel 718	F250C	(for sensor Z ONLY)	(Notes 2, 3)	NACE	6							
Inconel 718	1/4 – 18 NPT-f female	(for sensor Z ONLY)	(Notes 2, 3)	NACE	7							
Housing material and electrical connection - 10th character												
Aluminium alloy (barrel version)	1/2 – 14 NPT											A
Aluminium alloy (barrel version)	M20 x 1.5 (CM 20)											B
Aluminium alloy (barrel version)	Harting Han 8D connector	(general purpose only)	(Note 7)									E
Aluminium alloy (barrel version)	Fieldbus connector	(general purpose only)	(Note 7)									G
AISI 316 L ss (barrel version)	1/2 – 14 NPT											S
AISI 316 L ss (barrel version)	M20 x 1.5 (CM20)											T
AISI 316 L ss (barrel version)	Fieldbus connector	(general purpose only)	(Note 7)									Z
Aluminium alloy (DIN version)	M20 x 1.5 (CM20)	(not Ex d or XP)										J
Aluminium alloy (DIN version)	Harting Han 8D connector	(general purpose only)	(Note 7)									K
Aluminium alloy (DIN version)	Fieldbus connector	(general purpose only)	(Note 7)									W
Output/Additional options - 11th character												
HART digital communication and 4 to 20 mA	No additional options	(Notes 8, 9)										H
HART digital communication and 4 to 20 mA	Options requested by "Additional ordering code"	(Note 8)										1
PROFIBUS PA	No additional options	(Notes 8, 9)										P
PROFIBUS PA	Options requested by "Additional ordering code"	(Note 9)										2
FOUNDATION Fieldbus	No additional options	(Notes 8, 9)										F
FOUNDATION Fieldbus	Options requested by "Additional ordering code"	(Note 9)										3
HART and 4 to 20 mA Safety - certified to IEC 61508	No additional options	(Notes 8, 9, 16)										T
HART and 4 to 20 mA Safety - certified to IEC 61508	Options requested by "Additional ordering code"	(Note 8, 16)										8

ADDITIONAL ORDERING INFORMATION for model 266HSH

Add one or more 2-digit code(s) after the basic ordering information to select all required options

			XX	XX	XX
Accuracy					
0.04 % accuracy for applicable ranges	(Notes 17)	D2			
Drain/vent valve (material and position) (wetted parts)					
AISI 316 L ss	(Notes 2, 10, 16)	NACE	VA		
Hastelloy C-276™	(Notes 2, 11, 16)	NACE	VB		
Monel 400™	(Notes 2, 12, 16)	NACE	VC		
Hazardous area certifications					
ATEX Intrinsic Safety II 1 G Ex ia IIC T6/T5/T4; II 1 D Ex iaD 20 T85 °C and II 1/2D Ex iaD 21 T85 °C			(Notes 8, 9)	E1	
ATEX Explosion Proof Group II Category 1/2 G Ex d IIC T6 and Group II Category 1/2 D Ex tD A21 IP67 T85 °C			(Notes 8, 9, 13)	E2	
ATEX Type „N“ Group II Category 3 G Ex nL IIC T6/T5/T4 and Group II Category 3 D Ex tD A22 IP67 T85 °C			(Notes 8, 9)	E3	
Combined ATEX - Intrinsic Safety, Explosion Proof and Type „N“			(Notes 8, 9, 13)	EW	
Combined ATEX - Intrinsic Safety and Explosion Proof			(Notes 8, 9, 13)	E7	
Combined ATEX, FM Approvals (USA) and FM Approvals (Canada)			(Notes 8, 9, 13)	EN	
FM Approvals (Canada) approval			(Notes 8, 9, 13)	E4	
FM Approvals (USA) approval			(Notes 8, 9, 13)	E6	
FM Approvals (USA and Canada) Intrinsic Safety			(Notes 8, 9)	EA	
FM Approvals (USA and Canada) Explosion Proof			(Notes 8, 9, 13)	EB	
FM Approvals (USA and Canada) Nonincendive			(Notes 8, 9)	EC	
IECEX Intrinsic Safety Ex ia IIC T6/T5/T4; Ex iaD 20 T85 °C and Ex iaD 21 T85 °C;			(Notes 8, 9)	E8	
IECEX Explosion Proof Ex d IIC T6 and Ex tD A21 IP67 T85 °C (Ta= -50 to +75 °C)			(Notes 8, 9, 13)	E9	
IECEX Type „N“ Ex nL IIC T6/T5/T4			(Notes 8, 9)	ER	
Combined IECEX - Intrinsic Safety, Explosion Proof and Type „N“			(Notes 8, 9, 13)	EI	
Combined IECEX - Intrinsic Safety and Explosion Proof			(Notes 8, 9, 13)	EH	
NEPSI Intrinsic Safety Ex ia IIC T4~T6, DIP A20TA, T4~T6			(Notes 8, 9, 16)	EY	
NEPSI Explosion Proof Ex d IIC T6, DIP A21TA, T6			(Notes 8, 9, 13, 16)	EZ	
NEPSI Type „N“ Ex nL IIC T4~T6, DIP A22TA, TT6			(Notes 8, 9, 16)	ES	
Combined NEPSI - Intrinsic Safety, Explosion Proof and Type „N“			(Notes 8, 9, 13, 16)	EQ	
Combined NEPSI - Intrinsic Safety and Explosion Proof			(Notes 8, 9, 13, 16)	EP	
Other hazardous area certifications					
GOST (Russia) Ex ia			(Notes 8, 9, 16)	W1	
GOST (Russia) Ex d			(Notes 8, 9, 13, 16)	W2	
GOST (Kazakhstan) Ex ia			(Notes 8, 9, 16)	W3	
GOST (Kazakhstan) Ex d			(Notes 8, 9, 13, 16)	W4	
Inmetro (Brazil) Ex ia			(Notes 8, 9, 16)	W5	
Inmetro (Brazil) Ex d			(Notes 8, 9, 13, 16)	W6	
Inmetro (Brazil) Ex nL			(Notes 8, 9, 16)	W7	
Combined Inmetro (Brazil) - Intrinsic Safety, Explosion Proof and Type „N“			(Notes 8, 9, 13, 16)	W8	
GOST (Belarus) Ex ia			(Notes 5, 6, 16)	WF	
GOST (Belarus) Ex d			(Notes 8, 9, 13, 16)	WG	
Combined GOST (Belarus) - Intrinsic Safety and Explosion Proof			(Notes 8, 9, 13, 16)	WH	
Integral LCD					
Digital LCD integral display					L1
TTG (Through-The-Glass) digital LCD controlled display					L5

Model 266HSH Gauge

Model 266NSH Absolute

ADDITIONAL ORDERING INFORMATION for model 266HSH		XX	XX	XX	XX	XX	XX	XX	XX
Mounting bracket (shape and material)									
For pipe/wall mounting - Carbon steel	(Not suitable for AISI housing)	B6							
For pipe/wall mounting - AISI 316 L ss		B7							
Surge									
Surge/Transient Protector		S2							
Operating manual (up to 2 different selections allowed)									
German (ONLY FOR HART and PROFIBUS VERSIONS)					M1				
Italian (ONLY FOR HART VERSION)					M2				
Spanish (ONLY FOR HART VERSION)					M3				
French (ONLY FOR HART VERSION)					M4				
English					M5				
Chinese (ONLY FOR HART VERSION)					M6				
Swedish (ONLY FOR HART VERSION)					M7				
Polish (ONLY FOR HART VERSION)					M9				
Portuguese (ONLY FOR HART VERSION)					MA				
Turkish (ONLY FOR HART VERSION)					MT				
Plates language									
German					T1				
Italian					T2				
Spanish					T3				
French					T4				
Additional tag plate									
Supplemental wired-on stainless steel plate							I1		
Laser printing of tag on stainless steel plate							I2		
Configuration									
Standard – Pressure = inH2O/ psi at 68 °F; Temperature = deg. F								N2	
Standard – Pressure = inH2O/ psi at 39.2 °F; Temperature = deg. F								N3	
Standard – Pressure = inH2O/ psi at 20 °C; Temperature = deg. C								N4	
Standard – Pressure = inH2O/ psi at 4 °C; Temperature = deg. C								N5	
Custom								N6	
Preparation procedure									
Oxygen service cleaning (only available with inert fill)							(Note 16)		P1
Pmax =12 MPa for Galden, 9 MPa for Halocarbon for sensors E to S; 21 MPa for Galden for sensor V; Tmax=60 °C/140 °F									
Certificates (up to 2 different selections allowed)									
Inspection certificate EN 10204–3.1 of calibration (9-point)									C1
Inspection certificate EN 10204–3.1 of the cleanliness stage									C3
Inspection certificate EN 10204–3.1 of helium leakage test of the sensor module									C4
Inspection certificate EN 10204–3.1 of the pressure test									C5
Certificate of compliance with the order EN 10204–2.1 of instrument design									C6
Printed record of configured data of transmitter									CG
PMI test of wetted parts									CT

ADDITIONAL ORDERING INFORMATION FOR MODEL 266HSH				XX	XX	XX	XX
Approvals							
GOST (Russia) without Ex	(NOT APPLICABLE WITH ANY HAZARDOUS AREA CERTIFICATION)	(Note 16)	Y1				
GOST (Kazakhstan) without Ex	(NOT APPLICABLE WITH ANY HAZARDOUS AREA CERTIFICATION)	(Note 16)	Y2				
GOST (Belarus) without Ex	(NOT APPLICABLE WITH ANY HAZARDOUS AREA CERTIFICATION)	(Note 16)	Y4				
Chinese pattern without Ex	(NOT APPLICABLE WITH ANY HAZARDOUS AREA CERTIFICATION)	(Note 16)	Y5				
DNV approval		(Note 16)		YA			
Lloyd approval (PENDING)		(Note 16)		YB			
Approval for Custody transfer (PENDING)		(Note 16)		YC			
Material traceability							
Certificate of compliance with the order EN 10204–2.1 of process wetted parts							H1
Inspection certificate EN 10204–3.1 of process wetted parts							H3
Test report EN 10204–2.2 of pressure bearing and process wetted parts							H4
Connector							
Fieldbus 7/8 in. (Recommended for FOUNDATION Fieldbus) - (supplied loose without mating female plug)		(Notes 9, 14)					U1
Fieldbus M12x1 (Recommended for PROFIBUS PA) - (supplied loose without mating female plug)		(Notes 9, 14)					U2
Harting Han 8D – straight entry - (supplied loose)		(Notes 8, 14)					U3
Harting Han 8D – angle entry - (supplied loose)		(Notes 8, 14)					U4

Note 1: Suitable for oxygen service

Note 2: Not available with Sensor code V

Note 3: Not available with sensor code E to S

Note 4: Not available with diaphragm code M, T, C, D, 4, 5

Note 5: Not available with diaphragm code S, A, L, M, C, 4, 8, 9, I

Note 6: Not available with diaphragm code S, K, T, A, F, D, L, P, 5, E, G, 8, 9, I

Note 7: Select type in additional ordering code

Note 8: Not available with Housing code G, Z, W

Note 9: Not available with Housing code E, K

Note 10: Not available with Process connection code E, K, D, F, C, 1, 2, 3

Note 11: Not available with Process connection code B, T, A, P, N, 1, 2, 3

Note 12: Not available with Process connection code E, K, D, F, C, B, T, A, P, N

Note 13: Not available with Housing code J, K, W

Note 14: Not available with Housing code A, B, S, T, J

Note 15: Not available with Sensor code E

Note 16: Not available with Sensor code Z

Note 17: Not available with Sensor code E, S, V, Z

Standard delivery items (can be differently specified by additional ordering code)

- No drain/vent valves
- General purpose (no electrical certification)
- No display, no mounting bracket, no surge protection
- Multilanguage short-form operating instruction manual and labels in english
- Configuration with kPa and deg. C units
- No test, inspection or material traceability certificates

Model 266HSH Gauge

Model 266NSH Absolute

BASIC ORDERING INFORMATION model 266NSH Absolute Pressure Transmitter

Select one character or set of characters from each category and specify complete catalog number.

Refer to additional ordering information and specify one or more codes for each transmitter if additional options are required.

BASE MODEL - 1 st to 6 th characters			2 6 6 N S H	X	X	X	X	X
Absolute Pressure Transmitter – BASE ACCURACY 0.075 %								
SENSOR - Span limits - 7 th character								continued see next page
1.1 and 65 kPa	11 and 650 mbar	8 and 480 mmHg		G				
2.67 and 160 kPa	26.7 and 1600 mbar	20 and 1200 mmHg		H				
10 and 600 kPa	0.1 and 6 bar	1.45 and 87 psi		M				
40 and 2400 kPa	0.4 and 24 bar	5.8 and 348 psi		P				
134 and 8000 kPa	1.34 and 80 bar	19.4 and 1160 psi		Q				
267 and 16000 kPa	2.67 and 160 bar	38.7 and 2320 psi		S				
Diaphragm material / Fill fluid (wetted parts) - 8 th character								
AISI 316 L ss	Silicone oil			NACE	S			
Hastelloy C-276™	Silicone oil			NACE	K			
AISI 316 L ss	Inert fluid - Galden	(Note 1)		NACE	A			
Hastelloy C-276™	Inert fluid - Galden	(Note 1)		NACE	F			
AISI 316 L ss	Inert fluid - Halocarbon	(Note 1)		NACE	L			
Hastelloy C-276™	Inert fluid - Halocarbon	(Note 1)		NACE	P			

BASIC ORDERING INFORMATION model 266NSH Absolute Pressure Transmitter				2	6	N	S	H	X	X	X
Process connection (wetted parts) - 9th character											
AISI 316 L ss	1/2 – 14 NPT-f female			NACE						B	
AISI 316 L ss	1/2 – 14 NPT-f male			NACE						T	
AISI 316 L ss	DIN EN837-1 G 1/2 B			NACE						P	
AISI 316 L ss	Adapter straight (180°) entry (not available with bracket)			NACE						A	
AISI 316 L ss	Adapter angle (90°) entry			NACE						N	
Hastelloy C-276™	1/2 – 14 NPT-f female		(Note 3)	NACE						E	
Hastelloy C-276™	1/2 – 14 NPT-f male		(Note 3)	NACE						K	
Hastelloy C-276™	DIN EN837-1 G 1/2 B		(Note 3)	NACE						D	
Hastelloy C-276™	Adapter straight (180°) entry (not available with bracket)		(Note 3)	NACE						F	
Hastelloy C-276™	Adapter angle (90°) entry		(Note 3)	NACE						C	
Housing material and electrical connection - 10th character											
Aluminium alloy (barrel version)	1/2 – 14 NPT										A
Aluminium alloy (barrel version)	M20 x 1.5 (CM 20)										B
Aluminium alloy (barrel version)	Harting Han 8D connector	(general purpose only)			(Note 4)						E
Aluminium alloy (barrel version)	Fieldbus connector	(general purpose only)			(Note 4)						G
AISI 316 L ss (barrel version)	1/2 – 14 NPT										S
AISI 316 L ss (barrel version)	M20 x 1.5 (CM20)										T
AISI 316 L ss (barrel version)	Fieldbus connector	(general purpose only)			(Note 4)						Z
Aluminium alloy (DIN version)	M20 x 1.5 (CM20)	(not Ex d or XP)									J
Aluminium alloy (DIN version)	Harting Han 8D connector	(general purpose only)			(Note 4)						K
Aluminium alloy (DIN version)	Fieldbus connector	(general purpose only)			(Note 4)						W
Output/Additional options - 11th character											
HART digital communication and 4 to 20 mA		No additional options							(Notes 5, 6)		H
HART digital communication and 4 to 20 mA		Options requested by "Additional ordering code"							(Note 5)		1
PROFIBUS PA		No additional options							(Notes 5, 6)		P
PROFIBUS PA		Options requested by "Additional ordering code"							(Note 6)		2
FOUNDATION Fieldbus		No additional options							(Notes 5, 6)		F
FOUNDATION Fieldbus		Options requested by "Additional ordering code"							(Note 6)		3
HART and 4 to 20 mA Safety - certified to IEC 61508		No additional options							(Notes 5, 6)		T
HART and 4 to 20 mA Safety - certified to IEC 61508		Options requested by "Additional ordering code"							(Note 5)		8

Model 266HSH Gauge

Model 266NSH Absolute

ADDITIONAL ORDERING INFORMATION for model 266NSH

Add one or more 2-digit code(s) after the basic ordering information to select all required options

	XX	XX	XX
Drain/vent valve (material and position) (wetted parts)			
AISI 316 L ss (Note7)	NACE	VA	
Hastelloy C-276™ (Note8)	NACE	VB	
Hazardous area certifications			
ATEX Intrinsic Safety II 1 G and II 1/2 G Ex ia IIC T6/T5/T4; II 1 D Ex iaD 20 T85 °C and II 1/2D Ex iaD 21 T85 °C	(Notes 5, 6)	E1	
ATEX Explosion Proof Group II Category 1/2 G Ex d IIC T6 and Group II Category 1/2 D Ex tD A21 IP67 T85 °C	(Notes 5, 6, 9)	E2	
ATEX Type „N“ Group II Category 3 G Ex nL IIC T6/T5/T4 and Group II Category 3 D Ex tD A22 IP67 T85 °C	(Notes 5, 6)	E3	
Combined ATEX - Intrinsic Safety, Explosion Proof and Type „N“	(Notes 5, 6, 9)	EW	
Combined ATEX - Intrinsic Safety and Explosion Proof	(Notes 5, 6, 9)	E7	
Combined ATEX, FM Approvals (USA) and FM Approvals (Canada)	(Notes 5, 6, 9)	EN	
FM Approvals (Canada) approval	(Notes 5, 6, 9)	E4	
FM Approvals (USA) approval	(Notes 5, 6, 9)	E6	
FM Approvals (USA and Canada) Intrinsic Safety	(Notes 5, 6)	EA	
FM Approvals (USA and Canada) Explosion Proof	(Notes 5, 6, 9)	EB	
FM Approvals (USA and Canada) Nonincendive	(Notes 5, 6)	EC	
IECEX Intrinsic Safety Ex ia IIC T6/T5/T4; Ex iaD 20 T85 °C and Ex iaD 21 T85 °C;	(Notes 5, 6)	E8	
IECEX Explosion Proof Ex d IIC T6 and Ex tD A21 IP67 T85 °C (Ta= -50 to +75 °C)	(Notes 5, 6, 9)	E9	
IECEX Type „N“ Ex nL IIC T6/T5/T4	(Notes 5, 6)	ER	
Combined IECEX - Intrinsic Safety, Explosion Proof and Type „N“	(Notes 5, 6, 9)	EI	
Combined IECEX - Intrinsic Safety and Explosion Proof	(Notes 5, 6, 9)	EH	
NEPSI Intrinsic Safety Ex ia IIC T4~T6, DIP A20TA, T4~T6	(Notes 5, 6)	EY	
NEPSI Explosion Proof Ex d IIC T6, DIP A21TA, T6	(Notes 5, 6, 9)	EZ	
NEPSI Type „N“ Ex nL IIC T4~T6, DIP A22TA, TT6	(Notes 5, 6)	ES	
Combined NEPSI - Intrinsic Safety, Explosion Proof and Type „N“	(Notes 5, 6, 9)	EQ	
Combined NEPSI - Intrinsic Safety and Explosion Proof	(Notes 5, 6, 9)	EP	
Other hazardous area certifications			
GOST (Russia) Ex ia	(Notes 5, 6)	W1	
GOST (Russia) Ex d	(Notes 5, 6, 9)	W2	
GOST (Kazakhstan) Ex ia	(Notes 5, 6)	W3	
GOST (Kazakhstan) Ex d	(Notes 5, 6, 9)	W4	
Inmetro (Brazil) Ex ia	(Notes 5, 6)	W5	
Inmetro (Brazil) Ex d	(Notes 5, 6, 9)	W6	
Inmetro (Brazil) Ex nL	(Notes 5, 6)	W7	
Combined Inmetro (Brazil) - Intrinsic Safety, Explosion Proof and Type „N“	(Notes 5, 6, 9)	W8	
GOST (Belarus) Ex ia	(Notes 5, 6)	WF	
GOST (Belarus) Ex d	(Notes 5, 6, 9)	WG	
Combined GOST (Belarus) - Intrinsic Safety and Explosion Proof	(Notes 5, 6, 9)	WH	
Integral LCD			
Digital LCD integral display			L1
TTG (Through-The-Glass) digital LCD controlled display			L5

ADDITIONAL ORDERING INFORMATION for model 266NSH		XX	XX	XX	XX	XX	XX	XX
Mounting bracket (shape and material)								
For pipe/wall mounting - Carbon steel	(Not suitable for AISI housing)	B6						
For pipe/wall mounting - AISI 316 L ss		B7						
Surge								
Surge/Transient Protector		S2						
Operating manual (up to 2 different selections allowed)								
German (ONLY FOR HART and PROFIBUS VERSIONS)			M1					
Italian (ONLY FOR HART VERSION)			M2					
Spanish (ONLY FOR HART VERSION)			M3					
French (ONLY FOR HART VERSION)			M4					
English			M5					
Chinese (ONLY FOR HART VERSION)			M6					
Swedish (ONLY FOR HART VERSION)			M7					
Polish (ONLY FOR HART VERSION)			M9					
Portuguese (ONLY FOR HART VERSION)			MA					
Turkish (ONLY FOR HART VERSION)			MT					
Plates language								
German			T1					
Italian			T2					
Spanish			T3					
French			T4					
Additional tag plate								
Supplemental wired-on stainless steel plate						I1		
Laser printing of tag on stainless steel plate						I2		
Configuration								
Standard – Pressure = inH2O/ psi at 68 °F; Temperature = deg. F							N2	
Standard – Pressure = inH2O/ psi at 39.2 °F; Temperature = deg. F							N3	
Standard – Pressure = inH2O/ psi at 20 °C; Temperature = deg. C							N4	
Standard – Pressure = inH2O/ psi at 4 °C; Temperature = deg. C							N5	
Custom							N6	
Preparation procedure								
Oxygen service cleaning (only available with inert fill)								P1
Pmax =12 MPa for Galden, 9 MPa for Halocarbon; Tmax=60 °C/140 °F								
Certificates (up to 2 different selections allowed)								
Inspection certificate EN 10204–3.1 of calibration (9-point)								C1
Inspection certificate EN 10204–3.1 of the cleanliness stage								C3
Inspection certificate EN 10204–3.1 of helium leakage test of the sensor module								C4
Inspection certificate EN 10204–3.1 of the pressure test								C5
Certificate of compliance with the order EN 10204–2.1 of instrument design								C6
Printed record of configured data of transmitter								CG
PMI test of wetted parts								CT

Model 266HSH Gauge

Model 266NSH Absolute

ADDITIONAL ORDERING INFORMATION FOR MODEL 266NSH		XX	XX	XX	XX
Approvals					
GOST (Russia) without Ex	(NOT APPLICABLE WITH ANY HAZARDOUS AREA CERTIFICATION)	Y1			
GOST (Kazakhstan) without Ex	(NOT APPLICABLE WITH ANY HAZARDOUS AREA CERTIFICATION)	Y2			
GOST (Belarus) without Ex	(NOT APPLICABLE WITH ANY HAZARDOUS AREA CERTIFICATION)	Y4			
Chinese pattern without Ex	(NOT APPLICABLE WITH ANY HAZARDOUS AREA CERTIFICATION)	Y5			
DNV approval			YA		
Lloyd approval (PENDING)			YB		
Approval for Custody transfer (PENDING)			YC		
Material traceability					
Certificate of compliance with the order EN 10204–2.1 of process wetted parts					H1
Inspection certificate EN 10204–3.1 of process wetted parts					H3
Test report EN 10204–2.2 of pressure bearing and process wetted parts					H4
Connector					
Fieldbus 7/8 in. (Recommended for FOUNDATION Fieldbus) - (supplied loose without mating female plug)		(Notes 6, 10)			U1
Fieldbus M12x1 (Recommended for PROFIBUS PA) - (supplied loose without mating female plug)		(Notes 6, 10)			U2
Harting Han 8D – straight entry - (supplied loose)		(Notes 5, 10)			U3
Harting Han 8D – angle entry - (supplied loose)		(Notes 5, 10)			U4

Note 1: Suitable for oxygen service

Note 2: NOT USED

Note 3: Not available with AISI 316 L ss diaphragm code S, A, L

Note 4: Select type in additional ordering code

Note 5: Not available with Housing code G, Z, W

Note 6: Not available with Housing code E, K

Note 7: Not available with Process connection code E, K, D, F, C

Note 8: Not available with Process connection code B, T, A, P, N

Note 9: Not available with Housing code J, K, W

Note 10: Not available with Housing code A, B, S, T, J

Standard delivery items (can be differently specified by additional ordering code)

- No drain/vent valves
- General purpose (no electrical certification)
- No display, no mounting bracket, no surge protection
- Multilanguage short-form operating instruction manual and labels in english
- Configuration with kPa and deg. C units
- No test, inspection or material traceability certificates

IMPORTANT REMARK FOR ALL MODELS

THE SELECTION OF SUITABLE WETTED PARTS AND FILLING FLUID FOR COMPATIBILITY WITH THE PROCESS MEDIA IS A CUSTOMER'S RESPONSIBILITY, IF NOT OTHERWISE NOTIFIED BEFORE MANUFACTURING.

NACE COMPLIANCE INFORMATION

- (1) The materials of constructions comply with metallurgical recommendations of NACE MR0175/ISO 15156 for sour oil field production environments. As specific environmental limits may apply to certain materials, please consult latest standard for further details. Selected materials also conform to NACE MR0103 for sour refining environments.
- (2) NACE MR-01-75 addresses bolting requirements in two classes:
 - Exposed bolts: bolts directly exposed to the sour environment or buried, encapsulated or anyway not exposed to atmosphere
 - Non exposed bolts: bolts exposed to the atmosphere.
 266 bolting identified by "NACE" are in compliance to the requirements of NACE MR-01-75 when considered "exposed bolting"

Model 266HSH Gauge
Model 266NSH Absolute

™ Hastelloy C-276 is a Cabot Corporation trademark
™ Monel is an International Nickel Co. trademark
™ Inconel is a Special Metals Corporation trademark
™ Galden is a Montefluos trademark
™ Halocarbon is a Halocarbon Products Co. trademark

Contact us

ABB Ltd.

Process Automation

Howard Road
St. Neots
Cambridgeshire PE19 8EU
UK
Tel: +44 (0)1480 475321
Fax: +44 (0)1480 217948

ABB Inc.

Process Automation

125 E. County Line Road
Warminster
PA 18974
USA
Tel: +1 215 674 6000
Fax: +1 215 674 7183

ABB Automation Products GmbH

Process Automation

Schillerstr. 72
32425 Minden
Germany
Tel: +49 551 905 534
Fax: +49 551 905 555

ABB S.p.A.

Process Automation

Via Statale 113
22016 Lenno (CO)
Italy
Tel: +39 0344 58111
Fax: +39 0344 56278

www.abb.com

Note

We reserve the right to make technical changes or modify the contents of this document without prior notice. With regard to purchase orders, the agreed particulars shall prevail. ABB does not accept any responsibility whatsoever for potential errors or possible lack of information in this document.

We reserve all rights in this document and in the subject matter and illustrations contained therein. Any reproduction, disclosure to third parties or utilization of its contents - in whole or in parts - is forbidden without prior written consent of ABB.

Copyright© 2012 ABB
All rights reserved

3KXP200015R1001



Sales



Service



Software