

PP904A & B and P246A Static Pressure Regulators; PP904B1017 Differential Pressure Transmitter

SERVICE DATA



General

Description

The PP904A and B Static Pressure Regulators are direct or reverse acting controllers used with pneumatic control devices to control the static, differential, or velocity pressure in central fan installations. The PP904A is used in two-pipe applications and the PP904B in one-pipe applications.

The PP904B1017 Differential Pressure Transmitter provides a precise pneumatic signal to a receiver or controller to control duct air velocity pressures in airflow applications.

The P246A Static Pressure Regulator is a double-throw center-off electrical switch actuated by static or differential pressure changes on a diaphragm. It operates with a Series 60 floating control motor to control dampers that regulate static or differential pressure in a central fan installation.

Specifications

PP904A and B Static Pressure Regulators

Setpoint Range:

Adjustable, 0.00 to ± 8 in. water column (0 to 1.99 kPa)

Throttling Range:

PP904A1001: Adjustable, 0.02 to 0.5 in. wc (0.005 to 0.125 kPa)

PP904A1035: Adjustable, 0.03 to 0.5 in. wc (0.007 to 0.125 kPa)

PP904B1009: Adjustable, 0.06 to 0.5 in. wc (0.015 to 0.125 kPa)

Air Consumption:

PP904A: 0.022 scfm (10.4 mL/s) at 18 psi (124 kPa)

PP904B: 0.021 scfm (9.9 mL/s) with external 0.007 in. (0.18 mm) restriction

Air Handling Capacity:

PP904A: 0.039 scfm with 1 psi drop (18 mL/s with 5 kPa drop)

PP904B1009: equivalent to 0.007 in. (0.18 mm) restrictor

Maximum Safe Air Pressure:
25 psi (175 kPa)

Maximum Safe Static Pressure:
28 in. wc (7 kPa)

Ambient Temperature Limits:
40 to 120F (4 to 49C)

PP904B1017 Differential Pressure Transmitter

Zero Adjustment:
0.00 to ±8.0 in. wc (0.00 to 1.99 kPa)

Span Adjustment:
0.06 to 1.0 in. wc (0.015 to 0.25 kPa)

Air Consumption:
0.021 scfm (9.9 mL/s) with external 0.007 in. (0.18 mm) restriction

Maximum Safe Air Pressure:
25 psi (175 kPa)

Maximum Safe Static Pressure:
28 in. wc (7 kPa)

Ambient Temperature Limits:
40 to 120F (4 to 49C)

P246A Static Pressure Regulators

Control Range:
Positive, negative, or differential pressure. 0.0 to ±6 in. wc (0 to 1.5 kPa)

Differential:
Adjustable 0.05 to 0.75 in wc (0.012 to 187 kPa). Factory set at 0.1 in. wc (0.025 kPa)

Maximum Safe Static Pressure:
28 in. wc (7 kPa)

Temperature Limits:
40 to 120F (4 to 49C)

Electric Switch rating:
1A at 24V ac

Application

The PP904A and B Controllers, when used with pneumatic control devices, control the static and differential pressures in a central fan installation (Table 1). The PP904B1017 is used as an adjustable-range differential pressure transmitters. The P246A regulator, when used in an electrical control system, controls the static pressure.

Table 1. Applications.

Static Pressure Control: PP904A and B (Fig. 1)	Flow Control: PP904B1017 and P246A
<p>Direct Acting: An increase in static pressure causes the PP904 to increase the branchline pressure.</p> <p>Reverse Acting: An increase in static pressure causes the PP904 to decrease the branchline pressure.</p>	<p>PP904B1017 (Fig. 2): This model is used as a transmitter and is adjusted to the exact velocity pressure range required. The output from the PP904B is the input to a controller, such as the RP920, which controls the damper.</p> <p>P246A (Fig. 3): When the static pressure exceeds the static pressure setting, the P246A completes an electrical circuit to a Series 60 damper motor. The motor positions the dampers to reduce the static pressure. When the static pressure reduces to the setpoint of the P246A, the electrical circuit is broken, stopping the motor in this new position. A second contact drives the motor in the opposite direction on a decrease in static pressure.</p>

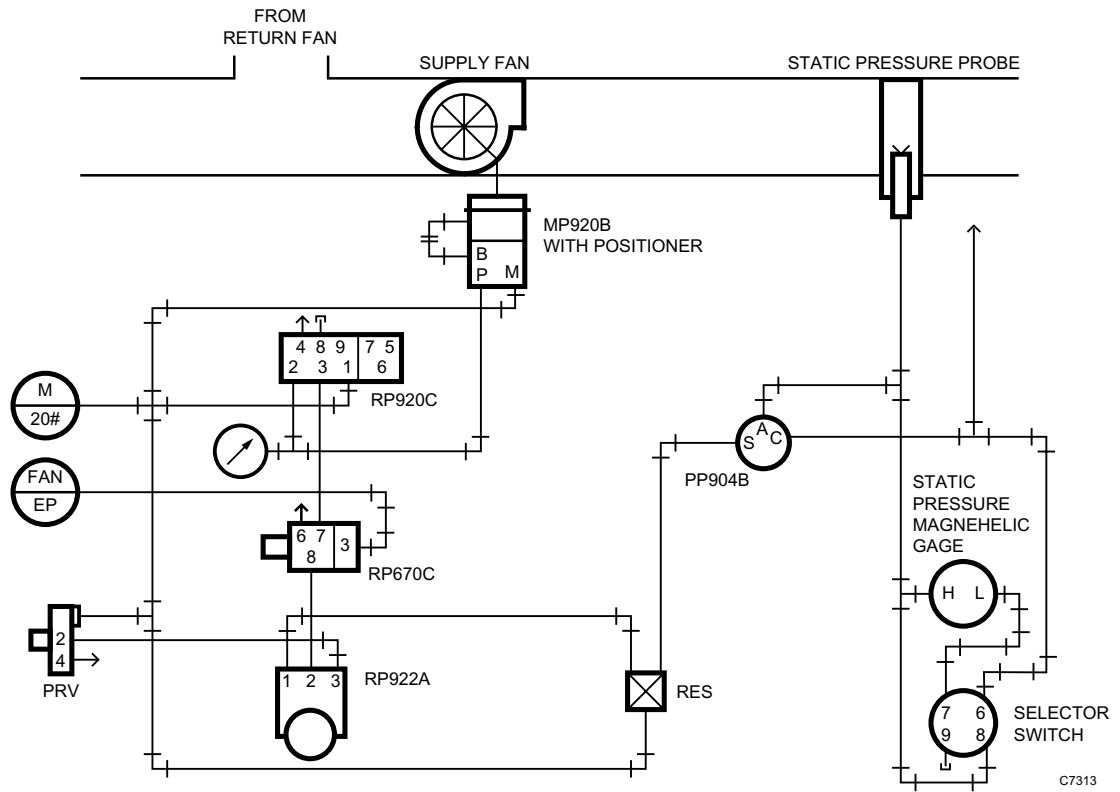

Fig. 1. PP904A or B Typical Static Pressure Operation.

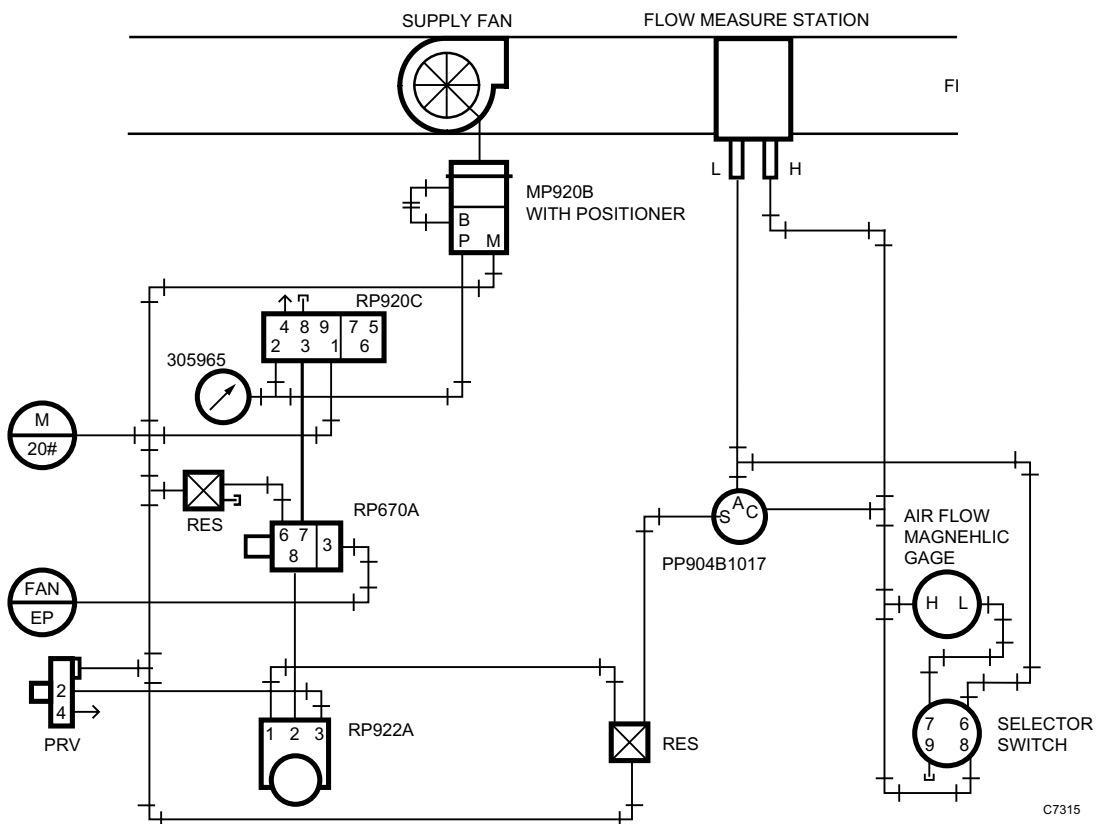

Fig. 2. PP904B1017 Typical Operation in Velocity (Flow) Application.

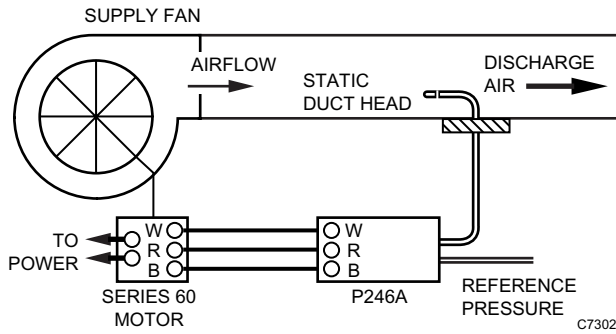

Fig. 3. P246A Typical Operation.

Operation

Static Pressure Control: PP904A1001 and PP904A1019

The PP904A1001 or PP904A1019 (Fig. 4) regulates static pressure by placing a reference pressure on one side of the diaphragm and static pressure on the other. For direct acting operation, the reference pressure, reflecting the pressure in the controlled space, is connected to the lower connector (2); a duct head assembly located in the duct, which senses the static pressure, is connected to the top connector (1). For reverse acting operation the reference pressure is connected to the top connector and the static pressure to the bottom connector.

When connected direct acting, an increase in the static pressure disturbs the force balance. The increased force on the diaphragm (3) exceeds the force of the setpoint springs (5) (6), and pulls down on the main lever (4). Two setpoint adjustment screws, one for course adjustment (8) and the other (9) for fine adjustment determine the compression on the setpoint springs. As the main lever moves downward, it comes into contact with the flapper (10) forcing the flapper closer to the nozzle (11).

Some of the main air entering the port (12) is diverted through the restriction (13) to the nozzle and the pilot

pressure chamber (14). The rest of the main air enters the chamber surrounding the branch check valve (15).

As the flapper is forced closer to the nozzle, air flow through the nozzle is reduced, increasing the pressure in the pilot pressure chamber. Increased pressure on the diaphragm (16) overcomes the check valve spring and opens the check valve (17) (View A) allowing main air to flow into the branch line (18). Pressure continues to build until the pressure on the branchline diaphragm balances the pressure on the pilot pressure chamber diaphragm (14) and closes the branchline check valve. The increased branchline pressure moves the damper toward the closed position reducing the static pressure in the duct.

The chamber surrounding the feedback bellows (20) is maintained at the same pressure as the branch line. As the branchline pressure increases the bellows pushes up on the feedback lever (21). The feedback lever operating through the throttling range adjustment screw (22) lifts up on the main lever, reducing the pressure on the flapper, bleeding of the pressure in the pilot pressure chamber and reducing the force on the pilot pressure chamber diaphragm (16) until the branchline check valve closes to maintain the branchline pressure at the new pressure.

A decrease in static pressure decreases the force on the top of the diaphragm (3). The decreased force on the diaphragm allow the setpoint springs to force the main lever (4) up and reduce the force on the flapper. The flapper spring lifts the flapper off the nozzle, bleeding the pilot pressure chamber and reducing the force on the pilot pressure chamber diaphragm (16).

Decreased pressure on the pilot pressure chamber diaphragm allows the branchline diaphragm (18) to open the branchline check valve guide (view B). Branchline air bleeds back through the center of the branchline check valve guide and exhaust through the vent (23).

The reduced pressure on the feedback bellows (20) allows the setpoint springs to pull the main lever down. This increases the force on the flapper which reduces the amount of air allowed to escape through the nozzle, increasing the pressure in the pilot chamber until the branchline check valve guide reseats against the check valve plug.

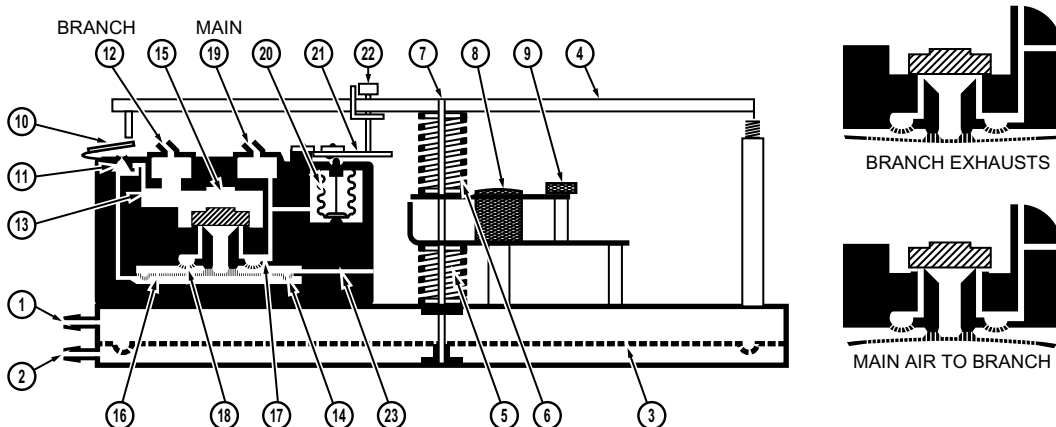

Fig. 4. Schematic Cutaway of the PP904A1001 and PP904A1019.

Maintenance Equipment Required

Test Panel as described in Pneumatic Airflow Control
Systems Checkout and Test 77-5031
CCT854: 50 cc Pressure Syringe
CCT863: 10 cc Pressure Syringe
CCT853A: Flexible Tubing to connect

Cleaning

Use a common household spray degreasing agent (such as Fantastic™) to remove dirt and grease from regulator.

Operation Check

Adjust the regulator setpoint and observe the operation of the damper operator. With the system in operation and the regulator in control, connect a static pressure gage with sufficient range for the application, across the two connectors (Fig. 7). If the gage reading is correct, relative to the setpoint, the system is operating properly.

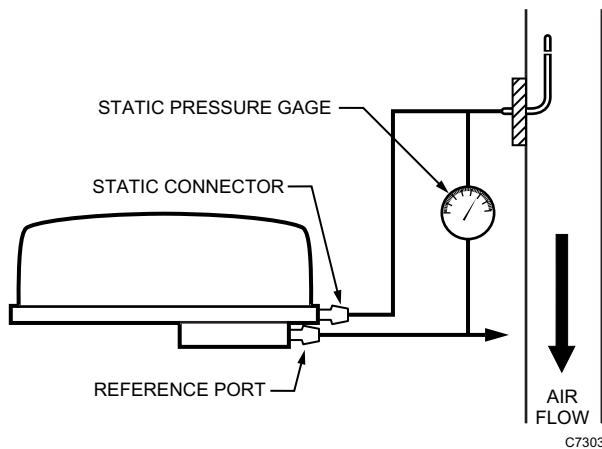

Fig. 7. Installing a Static Pressure Gage on the PP904A and B or P246A.

If you are unable to get the correct reading and all other related criteria are met (e.g., correct supply air and damper operation), check the calibration as follows:

Calibration

PP904A and B Static Pressure or Differential Control (Fig. 7)

- ① Set the throttling range to the desired setting.
- ② Set the setpoint indicator to the desired setting.
- ③ Connect the static pressure gage across the input ports (Fig. 7).

- ④ With the system in operation, check the static pressure gage for the desired pressure.
- ⑤ If the gage reading differs from the actual setpoint, adjust the large knurled screw (course adjustment, Item 35, Parts List) until the correct reading is reached.
- ⑥ On very low throttling ranges, it may be necessary to use the small knurled screw (Item 34, Parts List) for fine settings.
- ⑦ After making any changes in the setting, allow sufficient time for the system to stabilize and recheck the calibration.

NOTES:

1. The branchline pressure changes with every adjustment made.
2. Repeat the calibration procedures anytime the throttling range setting is changed.

PP904B Velocity Transmitter Applications

- ① Determine the "Min-Max" velocities to be encountered and the equivalent velocity pressures. Zero adjust the Min value for 3 psi (21 kPa) using the setpoint adjustment and span adjust the Max value to 15 psi (103 kPa) using the throttling range adjustment.
- ② Install a gage across the inputs. Use a syringe to apply and remove a signal on the high side pick-up with the low side open.

P246A

- ① Adjust the coarse adjustment screw to position the pointer at the desired setpoint.
- ② Connect the static pressure gage across the two static pressure head connectors (Fig. 7).
- ③ With the system in full operation, check the gage for a differential pressure reading. If the gage reading is correct, and the switching lever is between the contacts, the calibration is correct.
- ④ If the gage reading is different than the setpoint setting, check the calibration by manually positioning the motor until the regulator and gage setpoints agree.
- ⑤ Disconnect the motor leads and position the main lever, using the large knurled screws, to achieve a floating action of the switching lever.
- ⑥ The regulator is correctly calibrated. Reconnect motor leads.
- ⑦ If it is necessary to decrease the differential, adjust the contact point screw clockwise equally on the blue and white terminals. To increase the differential, back off the contact screws (counterclockwise).

Troubleshooting

A 1-in. draft gage, squeeze bulb is required for troubleshooting (Fig. 9).

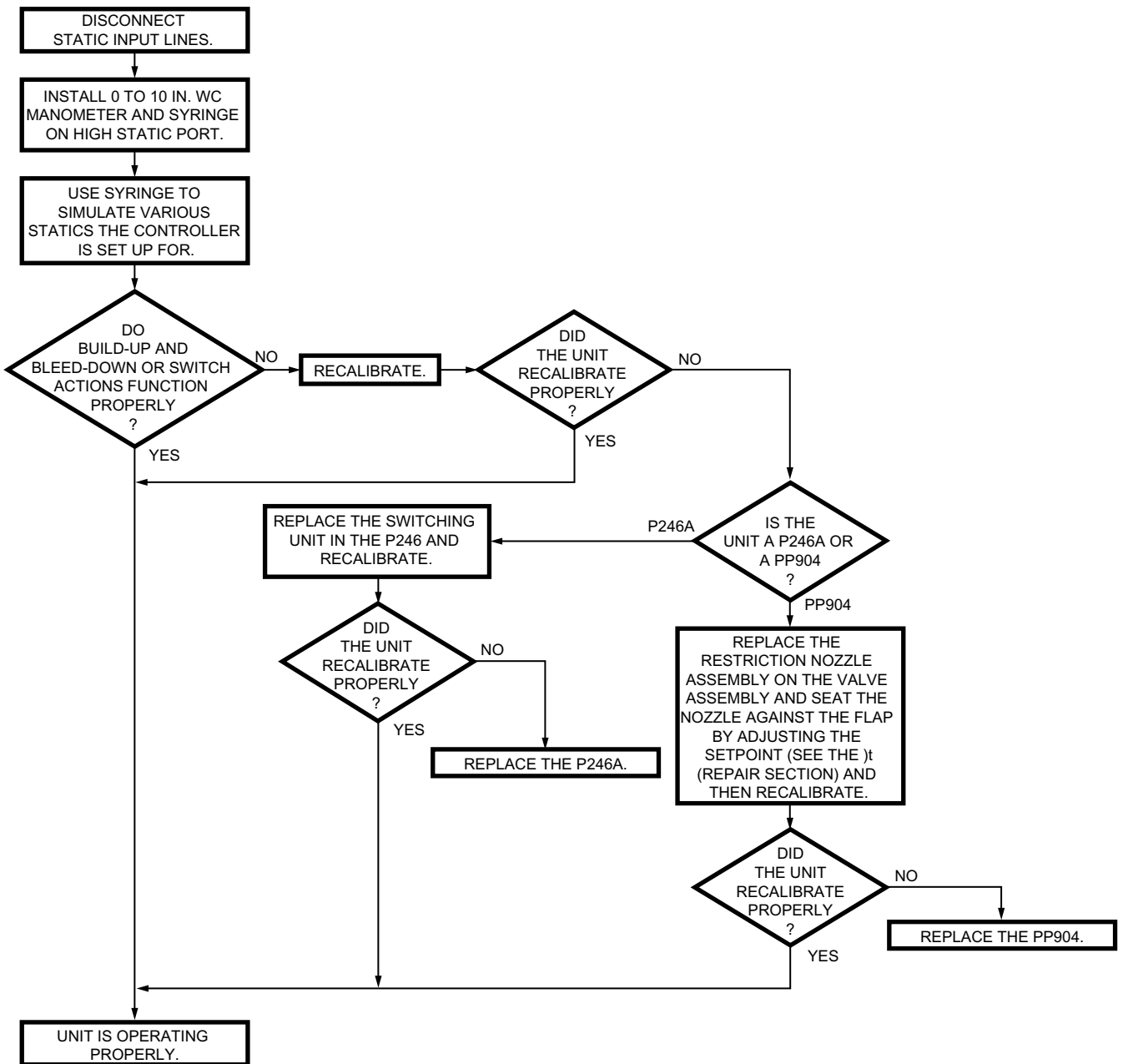

C7304

Fig. 8. Troubleshooting Chart.

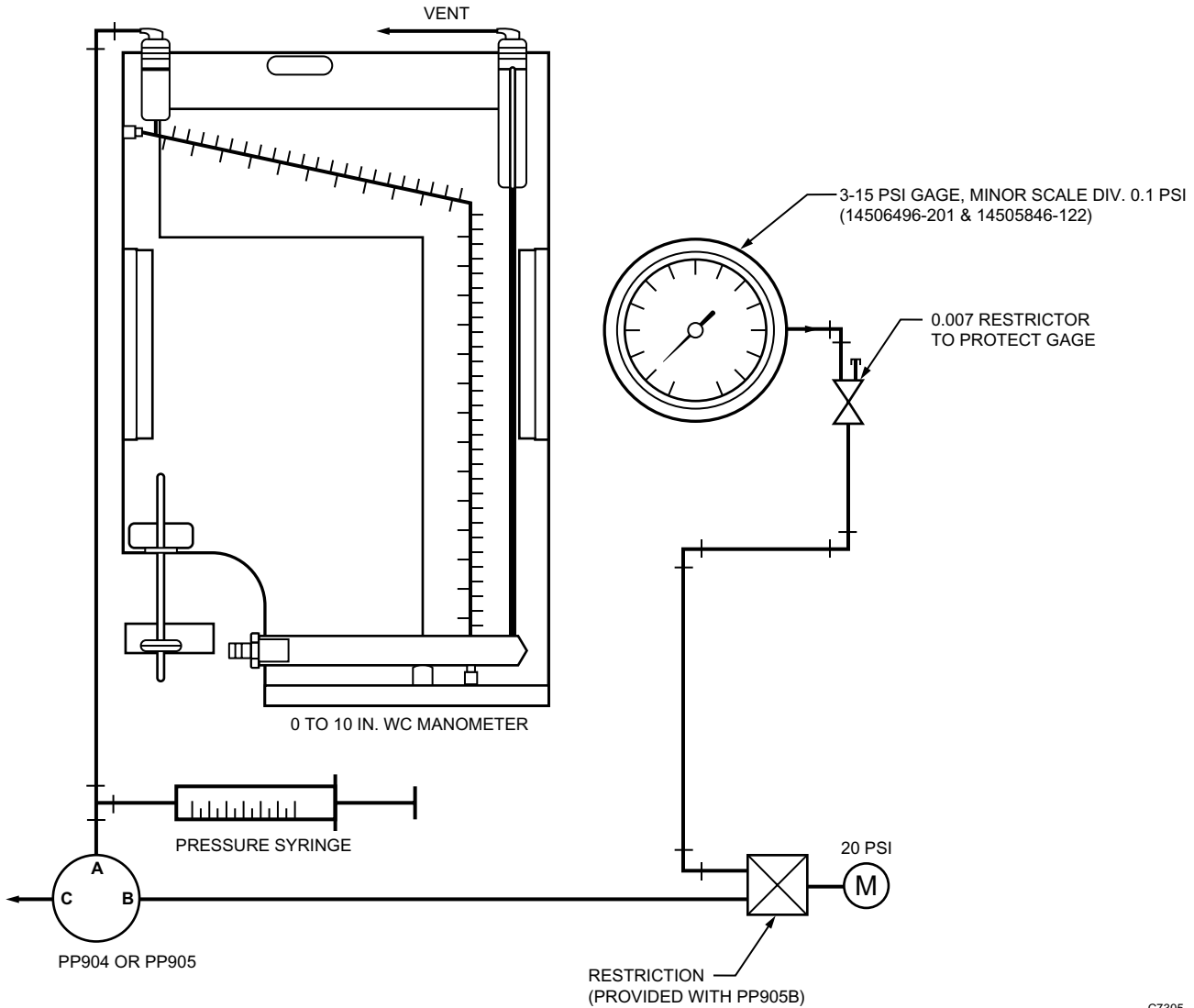

C7305

Fig. 9. Pressure Syringe Connection Diagram.

Repair

For assembly and disassembly, refer to exploded view diagram in parts section.

Seating Nozzle in PP904

- ❶ Adjust the setpoint until the flapper is firmly against the nozzle (Item 22, Fig. 10).
- ❷ Raise the flapper 1/2 in. and allow it to snap back.

Replacing PP904 Restriction Nozzle Assembly

Use Repair Kit Number 14002697-001 for all PP904As and PP904Bs.

NOTE: The instructions listed on the kit apply to round thermostats. The nozzle assembly replacement on the PP904 is similar. Discard the filters furnished in the kit.

Parts List and Accessories

Table 2. Parts List and Accessories.

Key	Description (Part Number)	Key	Description (Part Number)
1.*	Screw—No. 8-32 x 3/8 in. Pan Head Recessed	43.	Nut—No. 8-32 x 1/8 in. Hex
2.	Not Used	44.	Screw—No. 6-32 x 1/2 Pan Head Recessed
3.	Bracket—Mounting Left Hand Form	45.	Cap—Holding Ring (314840)
4.	Bracket—Mounting Right Hand Form	46.	Knob—Knurled Type, PP904A & B Only (314844)
5.	Plate Assembly (all models)	47.	Adjustment Indicator—PP904A & B Only
6.	Screw—No. 8-32 x 1/2 in. Pan Head Recessed	48.	Nut—TR Slide Adjustment, PP904A & B Only
	Screw—No. 8-32 x 1-1/4 in. for B1017	49.	Nut—No. 2-56 Hex
7.	Barb Connector 1/4-in. (6-mm) O.D. (CCT1607B)	50.	Pivot Assembly—Ball-point Head Type (314927A)
8.	Diaphragm (314670)	51.	Spring (314841)
9.	Screw—No. 6-32 x 1/4 in. Pan Head Recessed	52.*	Lever—Electrical Contact
10.	Disc—Diaphragm Holder	53.*	Washer—No. 2-56 Flat Brass
11.	Seal	54.*	Insulator—Contact Blade
12.	"O" Ring—Seal Type (311472)	55.*	Contact Blade Assembly (14001232-001)
13.	Spacer—Ring Type Adapter	56.*	Screw—No. 2-56 x 1/4 in. Round Head Slotted
14.	Diaphragm—Molded Neoprene (314848)	57.*	Leadwire Assembly—Common Connector
15.	Post	58.*	Contact Screw Assembly (24632A)
16.	Spring—Setpoint (314852)	59.*	Post—Terminal Contact
17.	Screw—Cover, No. 10-32 x 3/8 in. Acorn Washer Head	60.*	Washer—3/8 Brass Spacer
18.	Base	61.*	Insulator
19.	Scale	62.*	Washer—Blue Marker for Terminal Post
20.	Screw—No. 8-32 x 1/4 in. Pan Head Recessed	63.*	Lockwasher—No. 1108 Shakeproof
21.*	Nut—No. 4-40 Hex	64.*	Nut—No. 8-32 Hex, Brass Terminal Post
22.	Lever—Flapper, PP904A & B Only (314855)	65.*	Terminal—Wire Connection (314853)
23.*	Screw—No. 4-40 x 1/4 in. Pan Head Recessed	66.*	Nut—Terminal Knurled
24.	Plate (314843)	67.*	Washer—White Marker for Terminal Post
25.	Spring (314842)	68.*	Washer—Red Marker for Terminal Post
26.	Bracket	69.*	Screw—No. 8-32 x 3/4 in. Round Head Slotted, Common Connector
27.	Spring (303634)	70.*	Bracket
28.	Spring—Compression, Coarse Adjustment	71.*	Bracket—Insulator Holder
29.	Stud—No. 8-32	—	Cover (Not Shown)
30.	Nut—No. 8-32 x 1/4 in. Hex	72.	Tubing, Plastic 5/32-in. (3-mm) O.D.
31.	Lever—Scale Indicating	73.	Restrictor, Tee (315559F)
32.	Set Screw—No. 4-40 x 3/16 in. Socket	74.	Tubing, Plastic 5/32-in. (3-mm) O.D.
33.	Locknut—Inverted Tension (304721)	75.	Tubing, Plastic 5/32-in. (3-mm) O.D.
34.	Knob—Knurl, Fine Adjustment (314860)	76.	Capacity Relay (RP970A1008)
35.	Knob—Knurl, Coarse Adjustment (314859)	77.	Elbow 1/4- in. (6 mm) O.D. 90° (CCT 1638)
36.	Lever—Fine and Coarse Adjustment	78.	Brass Tee 1/4- in. (6 mm) O.D. (CCT1630B)
37.	Pointer—Scale	79.	Tubing, Plastic 1/4-in. (6-mm) O.D.
38.	Pin—Lever Base Connector	80.	Tubing, Plastic 5/32-in. (3-mm) O.D.
39.	Nut—Pushnut, Self-locking	81.	Barb Connector 5/32-in. (3-mm) O.D. (CCT1628B)
40.	Lever—Main	82.	Relay Clip (14003030-001)
41.	Screw—No. 8-32 x 3/4 in. Pan Head Recessed	83.	Washer
42.*	Nut—No. 8-32 Self-locking (except B1017)	84.	Tubing, Plastic 1/4-in. (6-mm) O.D.

* Available as assembled unit (314869) refer to Figure 13.

NOTES:

- See Figures 12, 13, and 14 for 314755B (PP904A) and 14003348-001 (PP904B) Pneumatic Valve Units.
- Obtain standard hardware parts locally.
- Parts 51 through 71 are for P246A only (Fig. 11).
- Parts 72 through 82 are for PP904A1035 only.

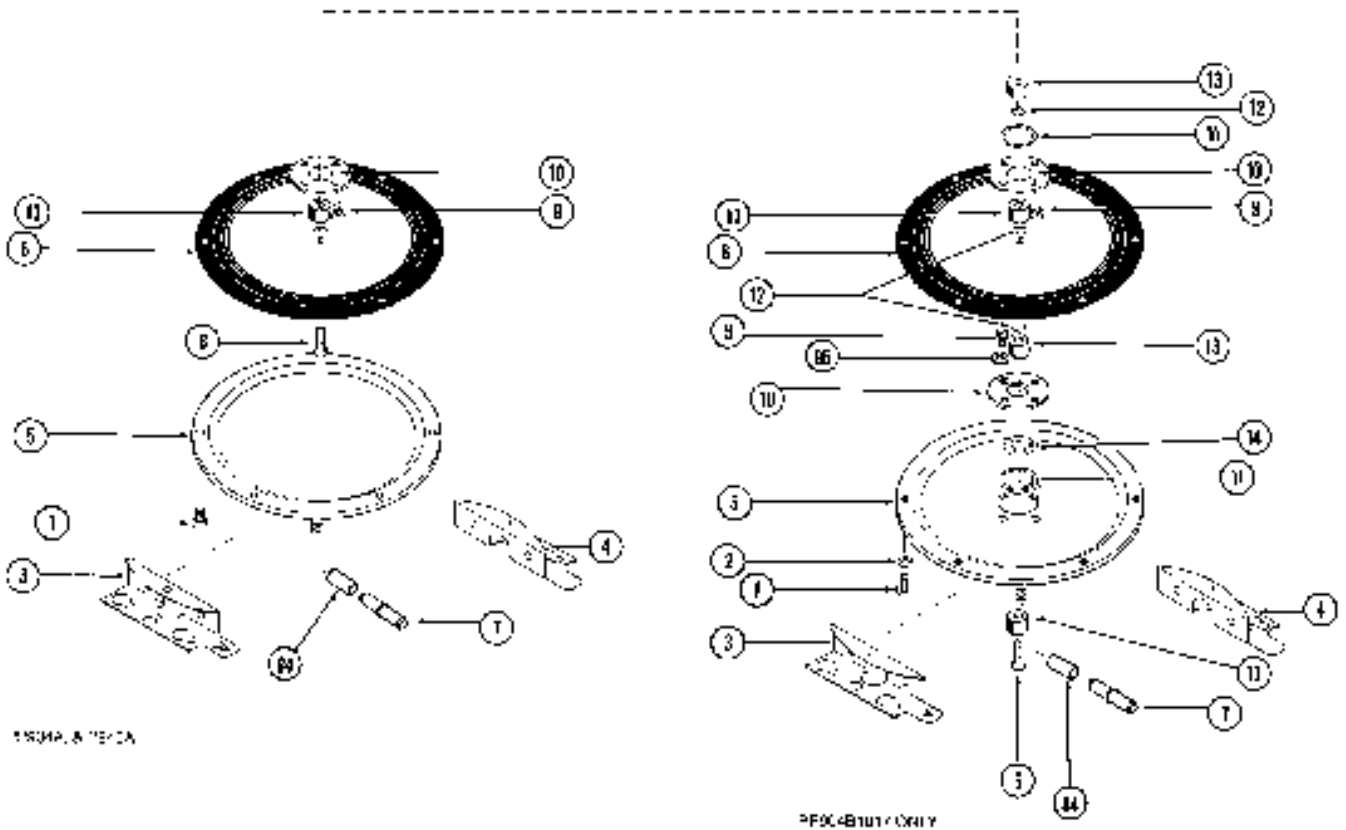
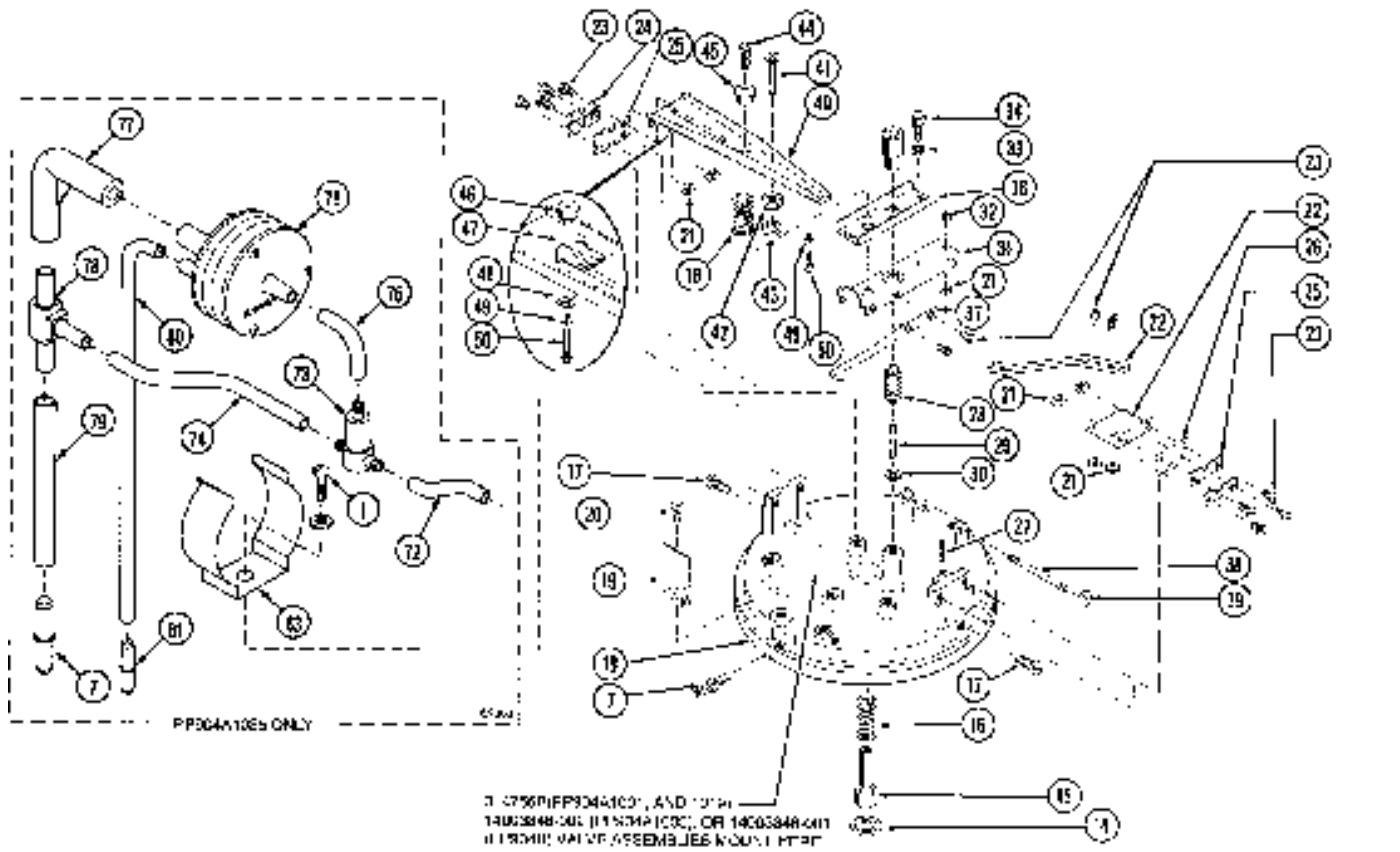

Fig. 10. PP904A, PP904B, and P246A Exploded View.

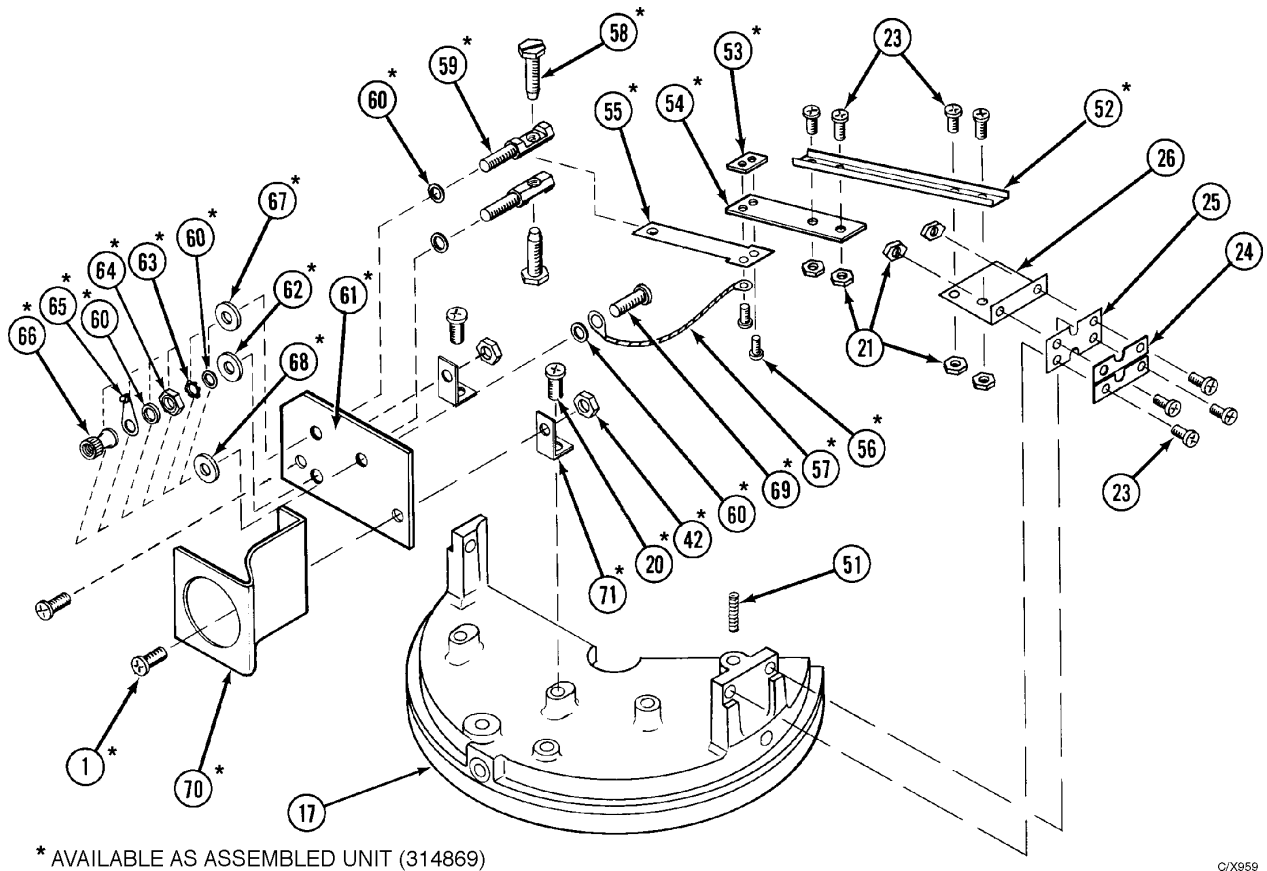
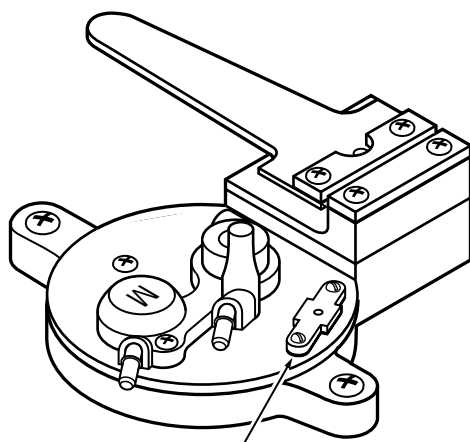

Fig. 11. P246A Electrical Switch Assembly.



RESTRICTION REPAIR KIT
(14002697-001)

C7310

Fig. 12. PP904A1001 Valve Assembly (314755B).

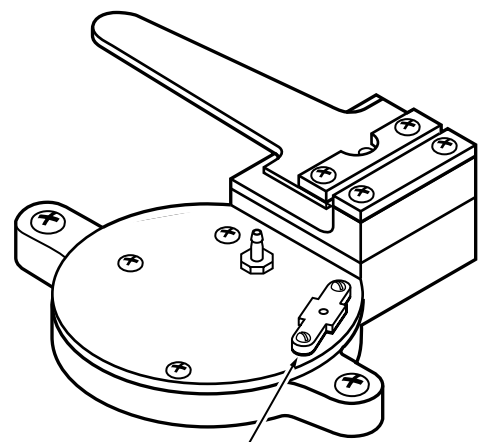

RESTRICTION REPAIR KIT
(14002697-001)

C7309

Fig. 13. PP904A1035 Valve Assembly (14003348-002).

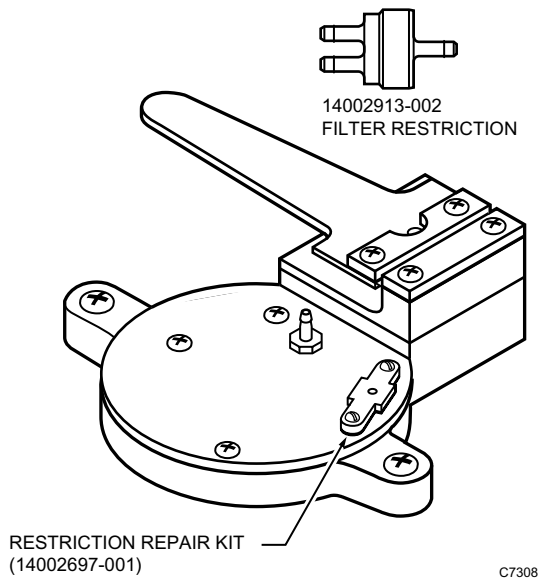

Fig. 14. PP904B Valve Assembly (14003348-001).

Honeywell

Home and Building Control
Honeywell Inc.
Honeywell Plaza
P.O. Box 524
Minneapolis, MN 55408-0524

Home and Building Control
Honeywell Limited-Honeywell Limitée
740 Ellesmere Road
Scarborough, Ontario
M1P 2V9

Helping You Control Your World